

VAXstation 4000 Model 60

Owner's and System Installation
Guide

Order Number: EK-PMARI-OM. A02

First Printing, November 1991
Second Printing, March 1994

Digital Equipment Corporation makes no representations that the use of its products in the manner described in this publication will not infringe on existing or future patent rights, nor do the descriptions contained in this publication imply the granting of licenses to make, use, or sell equipment or software in accordance with the description.

© Digital Equipment Corporation March 1994.

The postpaid Reader's Comments form at the end of this document requests your critical evaluation to assist in preparing future documentation.

The following are trademarks of Digital Equipment Corporation: DEC, DECconnect, DECnet, DECwindows, LN03, ThinWire, VAX, VAX DOCUMENT, VAXcluster, VAXstation, VMS, and the DIGITAL logo.

FCC NOTICE: This equipment has been tested and found to comply with the limits for a Class A digital device, pursuant to Part 15 of the FCC Rules. These limits are designed to provide reasonable protection against harmful interference when the equipment is operated in a commercial environment. This equipment generates, uses, and can radiate radio frequency energy and, if not installed and used in accordance with the instruction manual, may cause harmful interference to radio communications. Operation of this equipment in a residential area is likely to cause harmful interference, in which case users will be required to correct the interference at their own expense.

This document is available on CDROM.

S2531

This document was prepared using VAX DOCUMENT Version 2.1.

Contents

Preface	xi
1 Your VAXstation 4000 Model 60	
System Highlights	1-3
Available Options	1-7
2 Installing Your System	
Choose a Location	2-2
Prepare a Comfortable Work Environment	2-2
Preparing the Site	2-2
Keeping the Environment Comfortable	2-3
Finding a Comfortable Working Position	2-3
Unpack the System	2-5
Connect the Mouse and Keyboard	2-6
Attach Connectors and Other Cables	2-8
Turn on () the System Unit	2-17
Check the Automatic Test Display on the Screen	2-18
Other Steps for Using Your Workstation	2-21
Keep a Record of System Information	2-22
3 Using Your System	
Turning Your Workstation On and Off	3-2
Starting from a Disk	3-3
Adding and Handling Drives	3-4
Fixed Disk Drives	3-5
RRD42 Compact Disc Drive	3-6
Handling and Storing Compact Discs	3-7
Loading a Compact Disc into a Caddy	3-8
Inserting a Loaded Caddy	3-11
Removing a Compact Disc Caddy	3-12

RX26 Diskette Drive	3-13
Handling and Storing RX26 Diskettes	3-13
Write-Protecting Diskettes	3-15
Inserting and Removing Diskettes	3-16
TZK10 Tape Drive	3-18
Handling and Storing TZK10 Tape Cartridges	3-18
Write-Protecting TZK10 Tape Cartridges	3-19
TZK10 Controls and Indicator Lights	3-21
Inserting a TZK10 Tape Cartridge	3-22
Removing a TZK10 Tape Cartridge	3-23
DSW21 Synchronous Communications Adapter	3-24
Moving Your System	3-26

4 Connecting Your System Hardware to a Network

Testing Your Ethernet Subsystem	4-2
Reading the SHOW CONFIG Display	4-6
Connecting to an Ethernet Network	4-9
Troubleshooting the Network Connections	4-15
Removing a System from ThinWire Ethernet	4-16

5 Handling Problems

Identifying a Problem	5-2
Using the Troubleshooting Table	5-3
Reporting Problems to Your Digital Service Representative	5-10

6 Testing Your System

Identifying Faulty Components	6-2
Identifying the Problem	6-4
Reporting the Problem	6-6
Confirming Option Installation	6-7
Using the SHOW CONFIG Command	6-7
Using the SHOW DEVICE Command	6-9
Testing All Components Simultaneously	6-11
Rebooting the System After Testing	6-16

A Alternate Startup Procedures

Changing the Keyboard Language	A-2
Setting the Default Boot Device	A-3
Changing the Default Recovery Action	A-5
Setting the Default Boot Flags	A-6
Using an Alternate Console with Your System	A-7

B SCSI ID Settings

Recommended SCSI ID Settings	B-2
Resetting SCSI IDs	B-3

C Console Commands and the Password Security Feature

Console Commands	C-1
The Password Security Feature	C-4
Setting the Password	C-5
Enabling the Password	C-6
Disabling the Password	C-7
Changing the Password	C-7

D Hardware Specifications

E Associated Documents

F Port Pin-outs

G Error Messages

H DSW21 Synchronous Communications Adapter Installation Information for the United Kingdom

Cable Approval	H-1
Equipment Between the DSW21 Synchronous Communications Adapter and a Digital Circuit	H-2
Host Power Rating	H-3
Approved Service Specifications	H-4
BABT Host-Independent Approvals	H-6

Glossary

Index

Figures

1-1	Your VAXstation 4000 Model 60 System	1-2
1-2	Front of System	1-4
1-3	Back of System	1-5
2-1	System components	2-5
2-2	Connecting the Mouse and Keyboard	2-7
2-3	Assembling the T-connector	2-8
2-4	Attaching the Loopback and T-connectors	2-9
2-5	Attaching the Monitor Cable and Cord to the System	2-10
2-6	Attaching the Universal Strain Relief Strap	2-11
2-7	Attaching the Monitor Cable to the Monitor	2-12
2-8	Attaching the Monitor Power Cord	2-14
2-9	Attaching the System Power Cord	2-15
2-10	VMS Factory-Installed Software Sticker	2-16
2-11	On/Off Switch	2-17
2-12	Successful Automatic Test Display	2-18
2-13	Test Display with Error Message	2-19
2-14	Halt Button	2-20
3-1	Location of Additional Drives	3-4
3-2	RRD42 Compact Disc Controls and Indicators	3-6
3-3	Compact Disc Caddy Shutter	3-7
3-4	Removing the Protective Film on a Compact Disc Caddy	3-8
3-5	Opening the Compact Disc Caddy	3-9
3-6	Loading a Compact Disc into a Caddy	3-10
3-7	Inserting a Compact Disc Caddy into the Drive	3-11
3-8	Manually Removing a Compact Disc Caddy	3-12
3-9	RX26 Diskette Drive Controls and Indicator Lights	3-14
3-10	Write-Protecting a Diskette	3-15
3-11	Inserting a Diskette	3-16
3-12	Removing a Diskette	3-17
3-13	Write-Protecting TZK10 Tape Cartridges	3-20
3-14	TZK10 Controls and Indicators	3-21

3-15	Inserting the TZK10 Tape Cartridge	3-22
3-16	Removing the TZK10 Tape Cartridge	3-23
4-1	Successful Power-Up Display	4-3
4-2	Attaching the Network Label	4-4
4-3	SHOW CONFIG Display	4-5
4-4	SHOW CONFIG Display with Error	4-7
4-5	Network Switch	4-9
4-6	Adding ThinWire Cable	4-10
4-7	Connecting ThinWire Cable to ThinWire Port	4-11
4-8	Connecting Standard Ethernet Cable to Standard Ethernet Port	4-12
4-9	VAXstation Systems in a Work Group	4-13
4-10	DECconnect Faceplate	4-14
4-11	Removing a System from an Inactive ThinWire Segment ...	4-17
5-1	Diagnostic Lights	5-11
6-1	Power-Up Display with Error Message	6-3
6-2	SHOW CONFIG Display	6-8
6-3	SHOW DEVICE Display	6-9
6-4	Successful System Exerciser Test	6-13
6-5	System Exerciser Display with an Error Line	6-15
A-1	Changing the Keyboard Language	A-3
B-1	SCSI Device Switches	B-3
B-2	SCSI Device Jumpers	B-4
B-3	Status Information on SCSI IDs	B-6
F-1	Synchronous Communications Port Pins	F-7
H-1	Creepage Distance	H-7

Tables

1-1	Features: Front of System	1-4
1-2	Features: Back of System	1-6
1-3	VAXstation 4000 Model 60 Devices and Options	1-8
2-1	Connecting the Monitor Video Cable to the System Unit ...	2-13
2-2	Further Tasks	2-21
2-3	Your System Information	2-22
3-1	Storage Capacity of RX26 Diskettes	3-13
3-2	TZK10 Tape Cartridges	3-18

3-3	TZK10 Indicator Light States	3-21
3-4	Hardware Associated with the DSW21 Synchronous Communications Adapter	3-25
4-1	LCG Graphics Board Mnemonics for the SHOW CONFIG Command	4-6
5-1	Troubleshooting	5-4
5-2	Diagnostic Light Patterns of Common Problems	5-12
6-1	Component Numbers and Mnemonics in Power-Up and Self-Tests	6-4
6-2	Field Replaceable Unit Numbers and Definitions	6-6
6-3	Meaning of SHOW DEVICE Display	6-10
6-4	VMS Device Names	6-16
A-1	SCSI Boot Device Names	A-4
A-2	Values for Recovery Action	A-5
B-1	Recommended SCSI IDs for the System Unit	B-2
C-1	SHOW Commands	C-2
C-2	SET Commands	C-3
C-3	TEST Commands	C-3
C-4	Nonprivileged Console Commands	C-5
D-1	System Unit Dimensions (Diskless System)	D-2
D-2	System Specifications	D-2
D-3	System Electrical Specifications	D-2
D-4	System Environmental Specifications	D-3
D-5	RZ23L Fixed Disk Drive Specifications	D-4
D-6	RZ24 Fixed Disk Drive Specifications	D-5
D-7	RZ25 Fixed Disk Drive Specifications	D-7
D-8	RX26 Diskette Drive Specifications	D-9
D-9	RRD42 Compact Disc Drive Specifications	D-10
D-10	TZK10 Cartridge Tape Drive Specifications	D-11
D-11	DSW21 Synchronous Communications Adapter Specifications	D-12
E-1	VAXstation 4000 Bookreader Documents	E-1
E-2	Associated Printed Documents	E-2
F-1	Printer/Communications Port Pin-Outs	F-1
F-2	Asynchronous Communications Port Pin-Outs	F-2
F-3	DSW21 Synchronous Communications Port Pin-Outs	F-3
F-4	H3199 Multistandard Loopback Connector Pinning	F-7

G-1	Error Messages	G-2
H-1	Module Power	H-3
H-2	BABT Approved Service Specifications for the DSW21 Synchronous Communications Adapter for UK Compliance	H-5
H-3	Clearance and Creepage Distances	H-6

Preface

Purpose of This Guide

This guide describes how to install, use, and troubleshoot the hardware components of VAXstation 4000 Model 60 systems. This guide also includes information on how to connect your system to an Ethernet network.

Who Should Use This Guide

This guide is for anyone installing and using the VAXstation 4000 Model 60 workstation.

Structure of This Guide

This guide contains six chapters, eight appendixes, a glossary of technical terms, and an index. It is organized as follows:

- Chapter 1 provides an overview of the Model 60 workstation. It also introduces you to some of the features and options available.
- Chapter 2 describes how to set up the standalone system, provides ergonomic information about your work environment, and prepares you to begin using your system.
- Chapter 3 describes how to use your system, including the use of fixed disk drives, the RX26 diskette drive, the TZK10 tape drive, and the RRD42 compact disc drive.
- Chapter 4 tells you how to test the Ethernet subsystem and connect your system to a simple ThinWire Ethernet network or to a standard Ethernet network.
- Chapter 5 provides basic information to help you diagnose and solve problems.

- Chapter 6 explains how to run tests on all devices. It also describes how to confirm that you have installed an optional device correctly.
- Appendix A tells you how to set alternate startup procedures, including how to reboot your system and change the default recovery action. It also describes how to change your keyboard language setting.
- Appendix B provides information about setting SCSI IDs for devices inside the workstation system unit.
- Appendix C is a reference for experienced users. It describes console commands and how to use the password security feature.
- Appendix D provides hardware specifications for system components.
- Appendix E lists additional documents to help you get acquainted with your new system.
- Appendix F contains port pin-out information to add peripheral devices to your system unit.
- Appendix G lists the most common error messages and what action to take to solve simple problems.
- Appendix H includes installation information that is applicable to the United Kingdom.
- The glossary provides definitions for technical or unfamiliar terms.
- The index provides references to information within this guide. Use it to find specific topics covered in the manual.

Guide to Other Documentation

Guide to VAXstation 4000 Model 60 Documentation

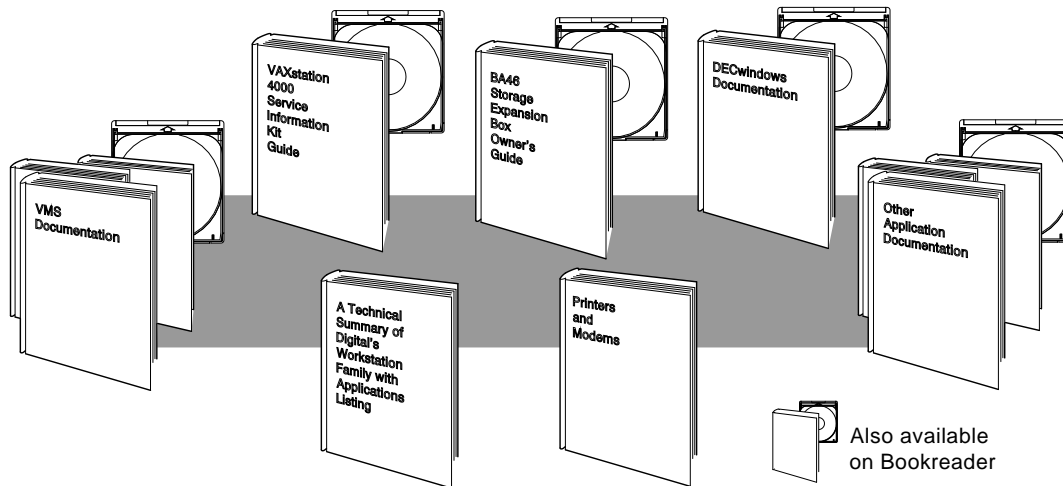
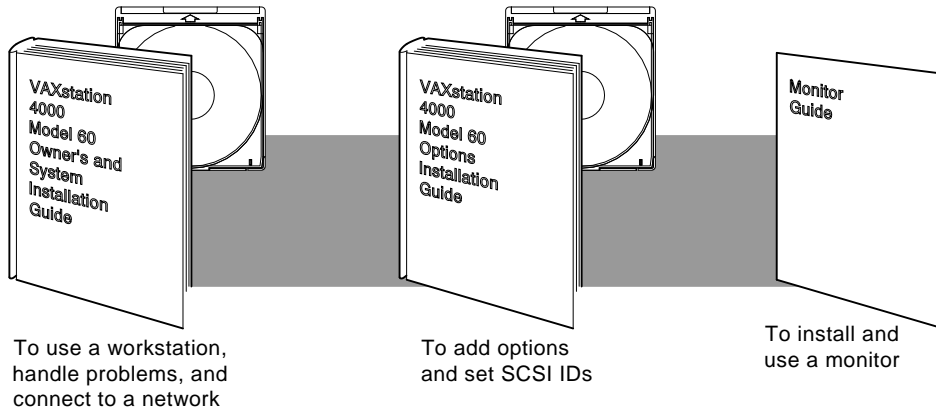

MLO-005480

Conventions

The following conventions are used in this guide:

`Return`

A key name is shown enclosed to indicate that you press a named key on the keyboard.

`Ctrl/x`

A sequence such as `Ctrl/x` indicates that you must hold down the key labeled Ctrl while you press another key or a pointing device button.

red type

In the printed book, red type in examples indicates commands and other system instructions that you must enter at the keyboard.

bold

In the online book (Bookreader), bold type in examples indicates information that you must enter at the keyboard.

UPPERCASE

Uppercase letters indicate a command that you must enter exactly as shown. For example:

```
>>> SHOW CONFIG Return
```

lowercase

Lowercase letters in commands indicate a variable value that you must provide. For example:

```
>>> SET PSWD your_password
```

Warning

Warnings contain information to prevent personal injury. Read these carefully.

Caution

Cautions provide information to prevent damage to equipment or software. Read these carefully.

Note

Notes provide general information about the current topic.

Icon and Symbol Descriptions

Throughout this guide, icons appear in the margins to signal the use of specific switches, connectors, or indicators on the system or the use of important procedures. The meanings of these icons are briefly explained here. Many of these icons appear as labels on the system itself.



Cross-Reference

Refer to another manual or another chapter in this book, then return to where you were to continue the procedure.



On/Off Switch (On)

Turn on (I) one or more devices, as described in the text.



On/Off Switch (Off)

Turn off (O) one or more devices, as described in the text.



SCSI Port

Attach a SCSI cable or SCSI terminator to this port.



Ethernet Network Switch

Follow instructions regarding the Ethernet network switch.



Halt Button

Press the halt button to put the system into console mode.



Handset Jack

Insert a telephone-style handset into this jack to use the audio input and output features of the system.



Audio Selector Switch

Move the audio selector switch up to use the handset or down to use the audio speaker.

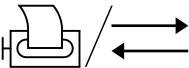

Printer/Communications Port

Connect a printer or hardcopy terminal cable to this port. You can also connect a communications device, such as a modem, to this port.

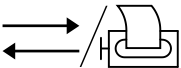

Communications/Printer Port

Attach a communications device such as a modem to this port. You can also connect a printer or hardcopy terminal to this port.



Remote Mouse/Keyboard Port

Attach the remote mouse or keyboard cable to this port. The remote cable option allows you to place your system up to 10 feet away from your monitor, keyboard, and pointing device for more desktop space. It is available through your Digital sales representative.



Keyboard Port

Insert the standard keyboard cable in this port.



Mouse Port

Insert a mouse, tablet, or other pointer cable in this port. The mouse is used to point to and select menu choices and other screen elements after installing windowing software on your system. To learn how to use your mouse, see your windowing software documentation.



Monitor Video Port

Insert the standard monitor video cable in this port.



Alternate Console Switch

Adjust this switch to the up position to use a terminal as an alternate console.



Diagnostic Lights

Note the status of these lights when you are reporting problems to your Digital service representative.



Standard Ethernet Port

Follow instructions regarding the standard Ethernet port.



ThinWire Ethernet Port

Follow instructions regarding the ThinWire Ethernet port.

1

Your VAXstation 4000 Model 60

The VAXstation 4000 Model 60 workstation offers all the advantages of an integrated computing environment based on Digital Equipment Corporation's VAX architecture. Figure 1-1 shows a configured system.

This chapter describes:

- System Highlights
- Available Options

Your VAXstation 4000 Model 60

Figure 1-1 Your VAXstation 4000 Model 60 System

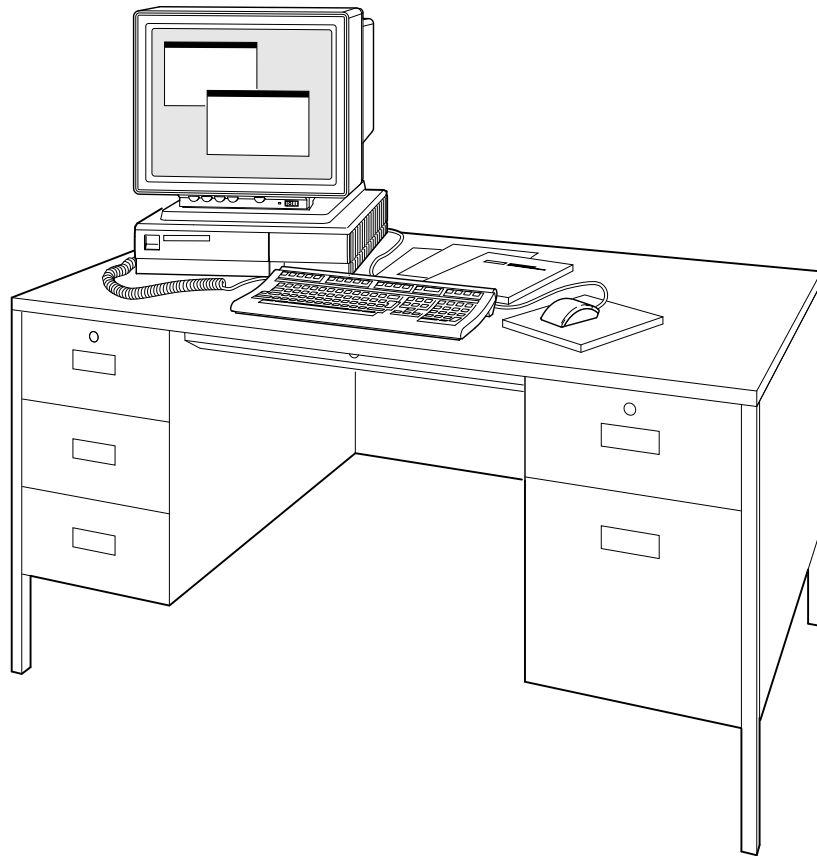

MLO-005091

System Highlights

The Model 60 workstation is a compact desktop system that consists of four components: a system unit, a monitor, a keyboard, and a mouse. The system offers the following special features:

- Desktop computing.
- Industry-standard personal productivity tools.
- Transparent access to local or distributed applications and resources.
- Timesharing.
- An optional DECwindows user interface that provides a consistent, windows-style of interaction in any application.
- Up to 104 megabytes of memory.
- A variety of options for increasing storage capacity, as well as adding communications, memory, enhanced graphics, and other capabilities to your system.
- Standard Ethernet and ThinWire Ethernet ports for connection to a DECnet network.
- A password security feature for additional system security in console mode.

The ports, switches, and indicators are shown in Figures 1–2 (the front of the system) and 1–3 (the back of the system).

Icons and symbols identify the ports, switches, and indicators on the front and back of the system unit. The icons are defined in the preface.

System Highlights

Figure 1-2 Front of System

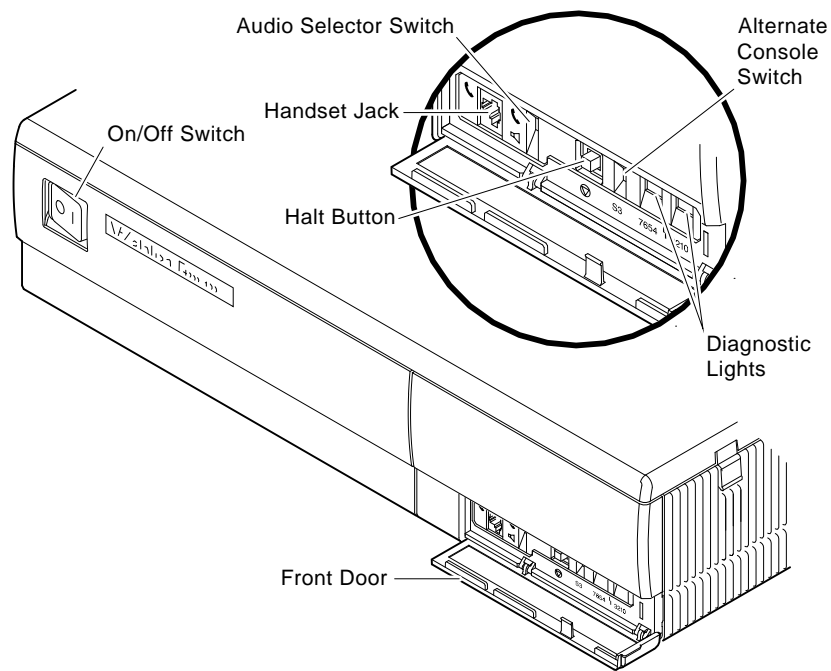

MLO-005090

Table 1-1 describes the ports, switches, and indicators on the front of the system unit. Table 1-2 describes the ports and switches on the back of the system unit.

Table 1-1 Features: Front of System

Feature	Function
On/off switch	Power switch for system unit (shown in Figure 1-2 in off (O) position).
Handset jack	For audio input and output.

(continued on next page)

Table 1–1 (Cont.) Features: Front of System

Feature	Function
Audio Selector switch	Used in the up position for the handset or the down position for the audio speaker.
Halt button	Used to put the system into console mode.
Alternate console switch	Used in the up position to select a terminal as an alternate console for testing purposes, or in the down position to return to normal use of the workstation monitor.
Diagnostic lights	Show status of system tests.

Figure 1–3 Back of System

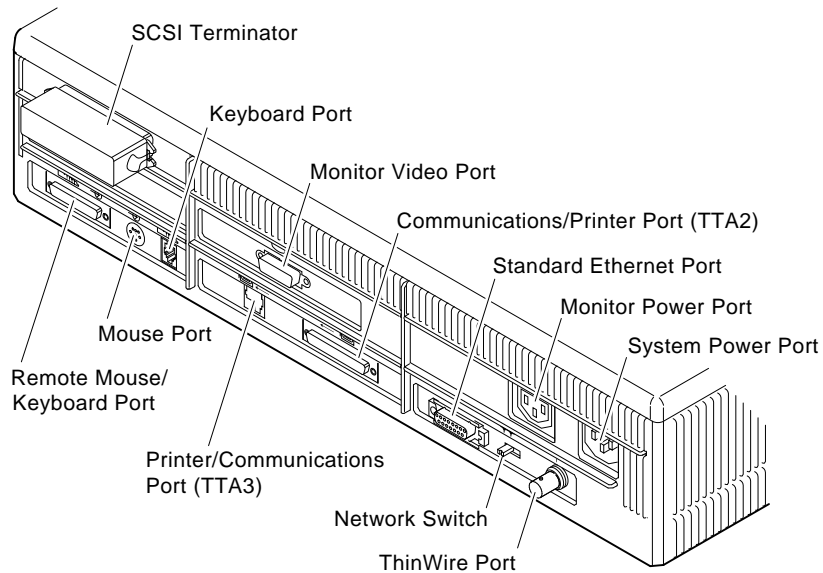

MLO-005089

System Highlights

Table 1–2 Features: Back of System

Feature	Function
SCSI port	Used to connect Small Computer System Interface (SCSI) peripheral devices to the system unit. Your system comes with a SCSI terminator pre-installed. Remove this terminator if you attach external options to the system unit or the expansion box.
Keyboard port	Used to connect the keyboard cable.
Monitor video port	Used to connect the monitor video cable.
Communications/printer port (TTA2)	Used primarily to connect an asynchronous communications device such as modem through an RS232 cable. The secondary use is to attach a printer or hardcopy terminal.
Printer/communications port (TTA3)	Used primarily to connect a printer or hardcopy terminal through an RS423 cable.

Note

VMS does not support modems on this port.

Standard Ethernet port	Used to connect to a standard Ethernet network.
Monitor power port	Used to connect the monitor power cord.
System power port	Used to connect the system power cord.
Remote mouse/keyboard port	Used to connect the remote mouse and keyboard cable.
Mouse port	Used to connect the mouse.

(continued on next page)

Table 1–2 (Cont.) Features: Back of System

Feature	Function
Network switch	Used to select ThinWire Ethernet or standard Ethernet networking options. Move the switch to the left for standard Ethernet or right for ThinWire Ethernet.
ThinWire Ethernet port	Used to connect to a ThinWire Ethernet network.

Available Options

Table 1–3 lists the options you can install inside or attach to the system unit, and/or install in the BA46 storage expansion box.

Available Options

Table 1–3 VAXstation 4000 Model 60 Devices and Options

Device or Option	System Box	Expansion Box
RZ23L, RZ24, RZ25 fixed disk drives	x	
RX26 diskette drive	x	
RRD42 compact disc drive	x	x
TZK10 cartridge tape drive	x	x
MS44 or MS44L memory	x	
TLZ04 (RDAT)		x
TZ30		x
RZ56, RZ58		x
SZ03 Storage Expansion Box	x	
DSW21 Synchronous Communications Adapter	x	
8-plane low-resolution Low Cost Graphics (LCG) board	x	
8-plane high-resolution color LCG board	x	
8-plane high-resolution dual-screen board	x	
Floor stand	x	x
Multiple-box rack	x	x
Tablet	x	
Modem	x	
Printer	x	
Dial box	x	
Button box (programmable function keyboard)	x	

Contact your Digital sales representative for more information about ordering any of these options.



For information about installing options in the system box, refer to the *VAXstation 4000 Options Installation Guide*. For information on installing BA46 storage expansion box options, refer to the *BA46 Storage Expansion Box Owner's Guide*, which is shipped with the expansion box.

2

Installing Your System

This chapter provides you with the following information:

- Step-by-step instructions on how to set up and install the system, as follows:
 1. Choose a Location
 2. Prepare a Comfortable Work Environment
 3. Unpack the System
 4. Connect the Mouse and Keyboard
 5. Attach Connectors and Other Cables
 6. Turn on (|) the System Unit
 7. Check the Automatic Test Display on the Screen
- Other Steps for Using Your Workstation , including where to find information on installing options, connecting to a network, installing the VMS operating system and DECwindows software, and running applications
- How to Keep a Record of System Information

Choose a Location

To keep your workstation functioning efficiently, choose a location that meets the following requirements:

- Connect your computer to a dedicated power source with an isolated ground. The power source must be 110–120 VAC or 220–240 VAC.
- Keep the room temperature between 15°C and 32°C (59°F and 90°F) and the relative humidity between 20% and 80%.
- Allow air to circulate around the workstation to prevent excess heat and to keep the system air vents clean.
- Do not place food or liquid on or near your equipment, and do not place your system directly on the floor. Dust and dirt damage system components.
- Keep your equipment away from heaters, photocopiers, direct sunlight, and dust particles.
- Let the equipment stabilize to room temperature before you turn it on.
- If you have two monitors, do not sit them too close together. Doing so may create a magnetic field that can distort the display on your screen or cause changes in color hues.

Prepare a Comfortable Work Environment

To make your work space as comfortable as possible:

- Prepare the site at which you will be working.
- Find a comfortable position in which to work.

Preparing the Site

Digital's video terminals have a number of built-in features to provide a more comfortable working environment. The following are some other suggestions for preparing your site.

Prepare a Comfortable Work Environment

Arrange the Lighting

- Avoid direct lighting or sunlight on the screen, which causes glare and reflections.
- Try to place lighting behind or to the side of your working position.
- Distribute available light evenly on all work surfaces.

Eliminate Distractions

- Background noise above 65 dBA is tiring. Sound-absorbing materials (curtains, carpeting, and acoustic tile) can help reduce background noise.
- Movement around the work area can be distracting. Use curtains or partitions behind the terminal and to the sides — at least 158 cm (5 ft) for a sitting position, 183 cm (6 ft) for a standing position.
- If you install several terminals near each other, keep them a minimum of 70 cm (28 in) apart (center to center), and preferably 122 cm (48 in) to 152 cm (60 in).

Keeping the Environment Comfortable

- Keep the office temperature between 20°C and 23°C (68°F and 74°F), at 30 to 70 percent relative humidity.
- Provide adequate air ventilation to operate the equipment and avoid fatigue.
- Control static electricity. Some sources of static electricity are clothing and carpeting materials (such as wool and nylon), and metal frame furniture.

Finding a Comfortable Working Position

Eyesight

- There is no evidence that eye damage can be caused by working at video terminals. Eye fatigue can be caused by a number of factors, such as glare, the image quality of the video display, uncomfortable furniture, and uncorrected eyesight.
- If your eyes cannot focus easily to read at different distances, you may need special glasses to focus at the distance between your working position and the screen.

Prepare a Comfortable Work Environment

- When working at the terminal, relax your eyes periodically by looking at distant objects.

Physical Discomforts

- Neck, shoulder, back, and arm discomfort may occur after working for prolonged periods at the terminal. These problems are related to posture and furniture rather than the terminal.
- Take periodic work breaks. Morning, lunch, and afternoon breaks meet most recommendations. Take advantage of work breaks to move around and do simple muscle-relaxing exercises.

Seating Position

- Use a seat that promotes proper posture, with adjustments for seat height and lower back support. Use a headrest, if needed.
- Place feet flat on the floor or footrest, with lower legs approximately vertical and thighs approximately horizontal. Place your weight on the buttocks, not thighs. Avoid compressing the area behind the knees, which could restrict blood flow.
- Keep your upper body erect and support your lower back with a backrest.
- Your upper arms should hang comfortably from your shoulder joints and straight down at the sides. Place your forearms within a 70 to 90 degree angle, so your elbows support your arm weight. Do not flex or extend your wrists more than 15 degrees.
- Incline your head downward, but no more than 15 to 20 degrees.
- *If you use a mouse:* Rest your hand on the mouse so that your wrist does not drag along the work surface. Operate the mouse close to your body's centerline. Leaning over to operate a mouse can be tiring.

Unpack the System

Figure 2-1 shows the basic components of your system.

Figure 2-1 System components

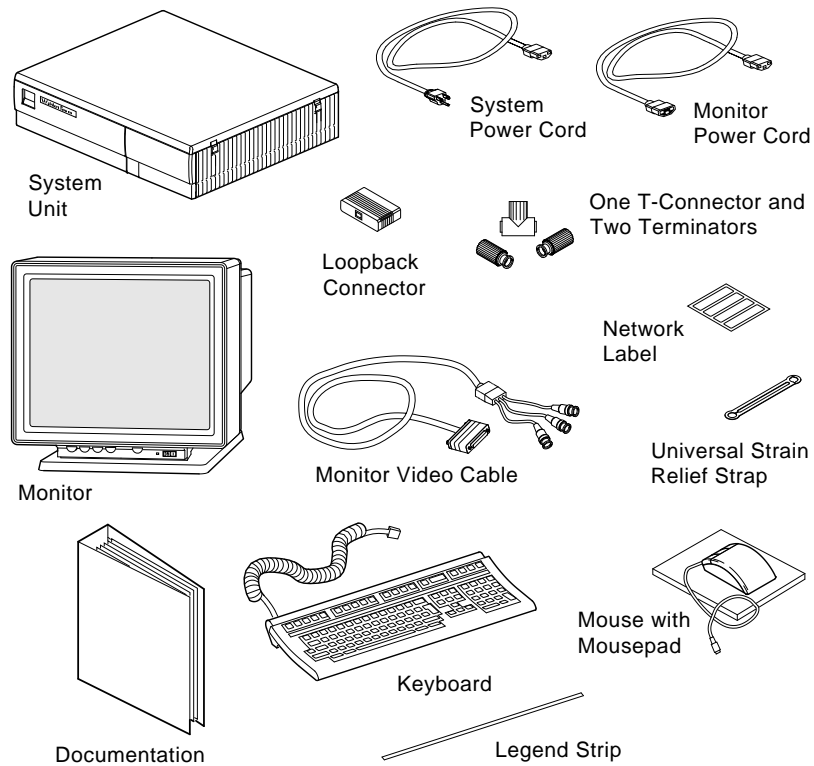

MLO-005311

Make sure you have all parts listed on the packing slip before you set up your system. If you are missing parts, contact your Digital sales representative.

Unpack the System

Notes

- The contents of your shipment may differ from those shown, depending on what options you ordered.
 - The monitor is heavy and is packed tightly in foam molds. Remove them carefully from the cartons.
 - Save the cartons and packaging material in case you ever want to ship your system to another location.
-

Connect the Mouse and Keyboard

Figure 2-2 shows how to:

1. Install the legend strip in the place provided on the keyboard.
2. Attach the mouse and keyboard cables.



Note

If you want to place your system unit away from your work area, you can order the remote cable kit and floor stand from your Digital sales representative. (See the *VAXstation 4000 Options Installation Guide* for installation information.)

Connect the Mouse and Keyboard

Figure 2-2 Connecting the Mouse and Keyboard

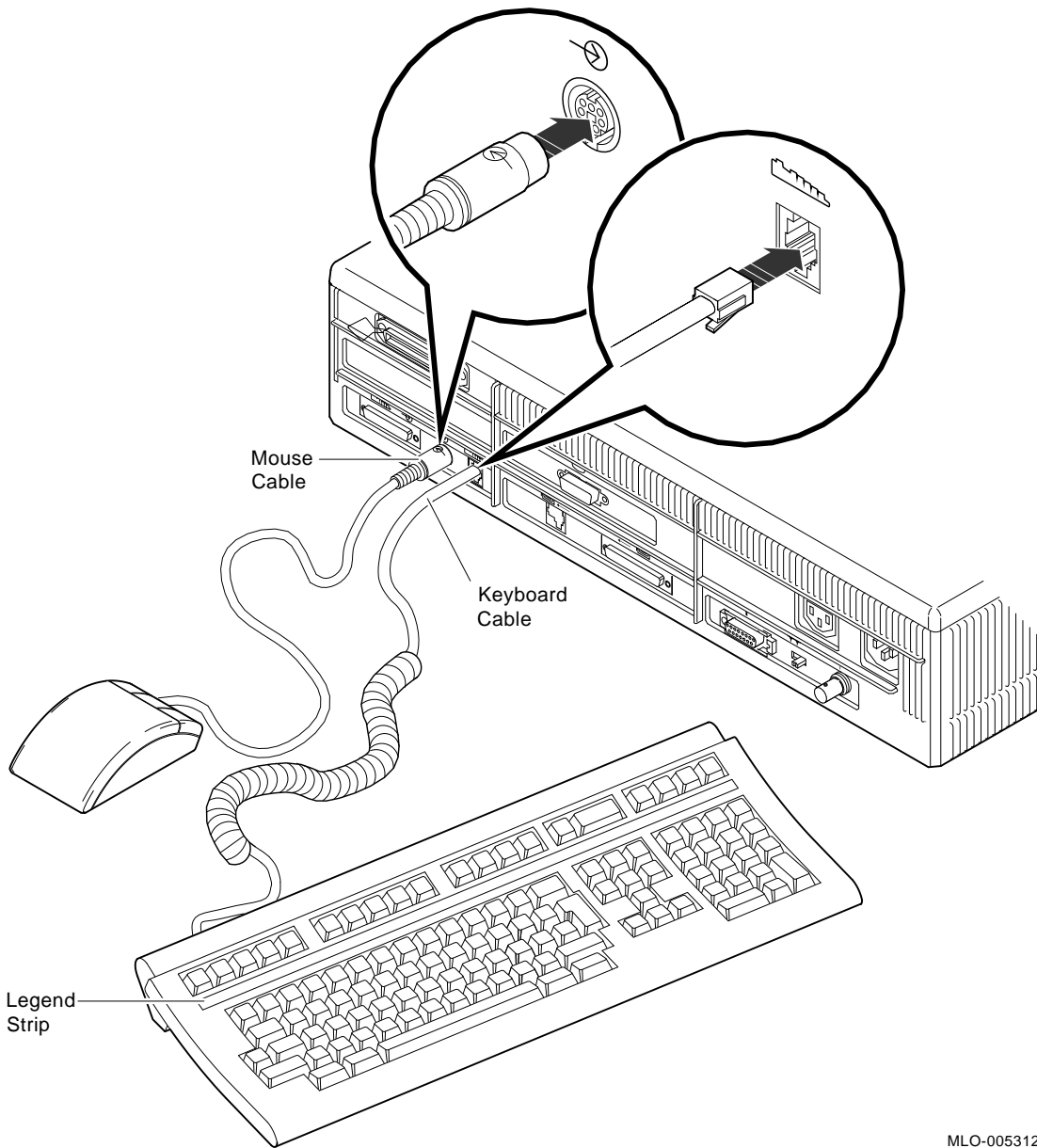

MLO-005312

Attach Connectors and Other Cables

Attach connectors and cables in the following order:

1. Attach the T-connector and the Ethernet loopback connector as follows:
 - a. Assemble the T-connector, as shown in Figure 2–3.

Figure 2–3 Assembling the T-connector

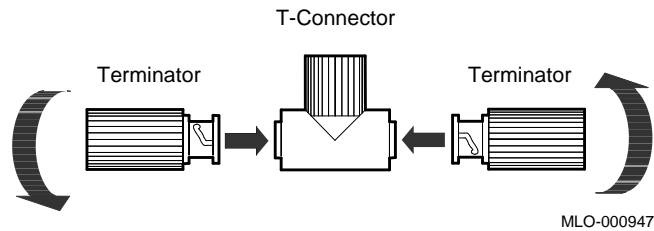

Attach Connectors and Other Cables

- b. Securely attach the T-connector to the ThinWire port and the loopback connector to the standard Ethernet port on the back of the system unit, as shown in Figure 2-4.

Figure 2-4 Attaching the Loopback and T-connectors

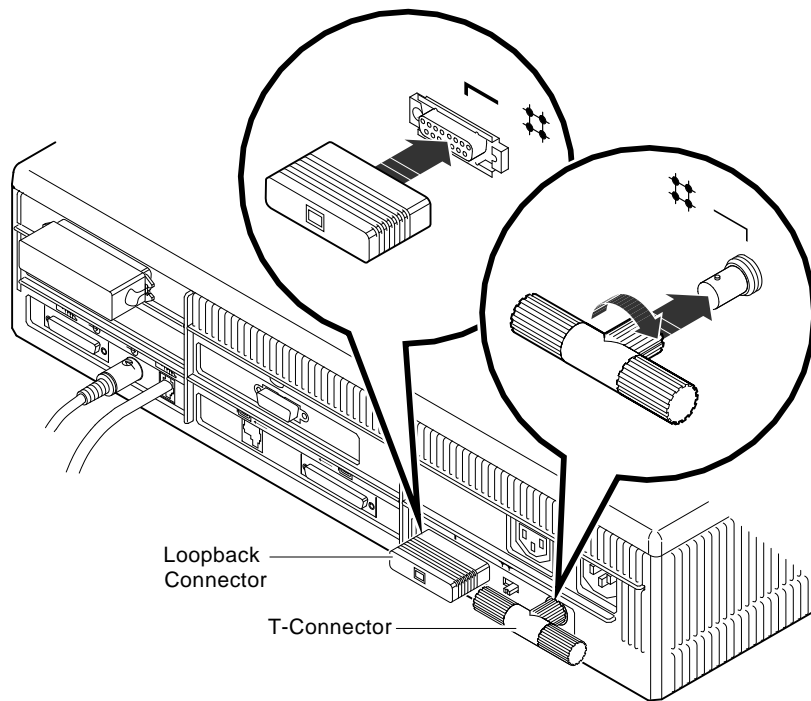

- c. Turn the T-connector to the right after you connect it to the system unit.

Attach Connectors and Other Cables



2. Attach the monitor video cable and power cord to the back of the system unit, as shown in Figure 2-5.

Figure 2-5 Attaching the Monitor Cable and Cord to the System

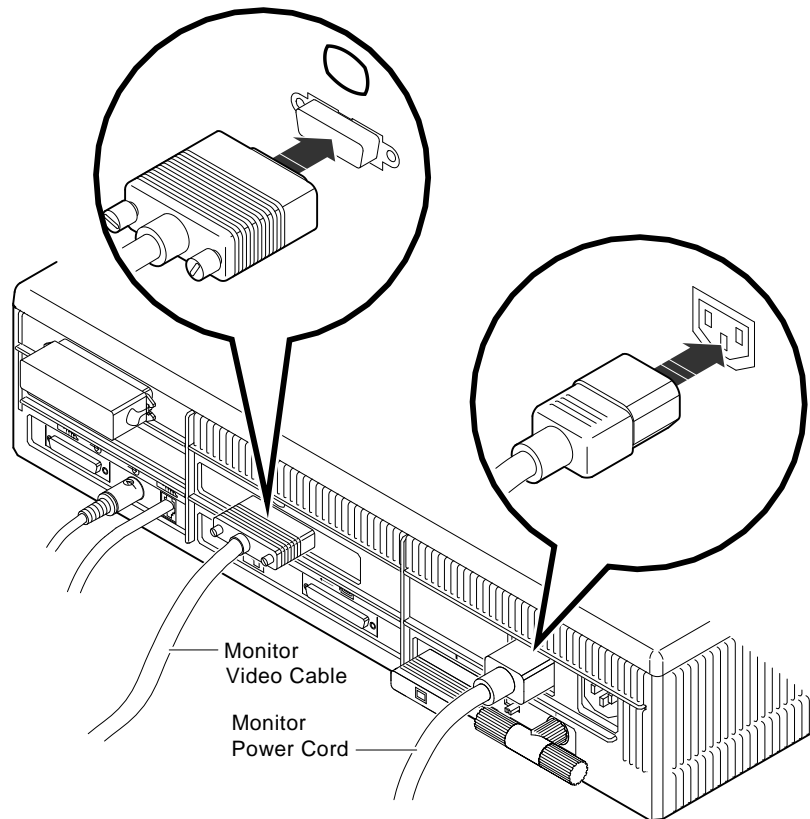

MLO-005314

Attach Connectors and Other Cables

3. Attach the universal strain relief strap (USRS) to the monitor video cable, as follows (this strap relieves strain from the video cables):
 - a. Insert the three BNC connectors and cable junction box of the video cable through the center slot of the strap, as shown in Figure 2-6. (The BNC connectors are the connectors that you twist to connect the monitor cables to the system unit.)

Figure 2-6 Attaching the Universal Strain Relief Strap

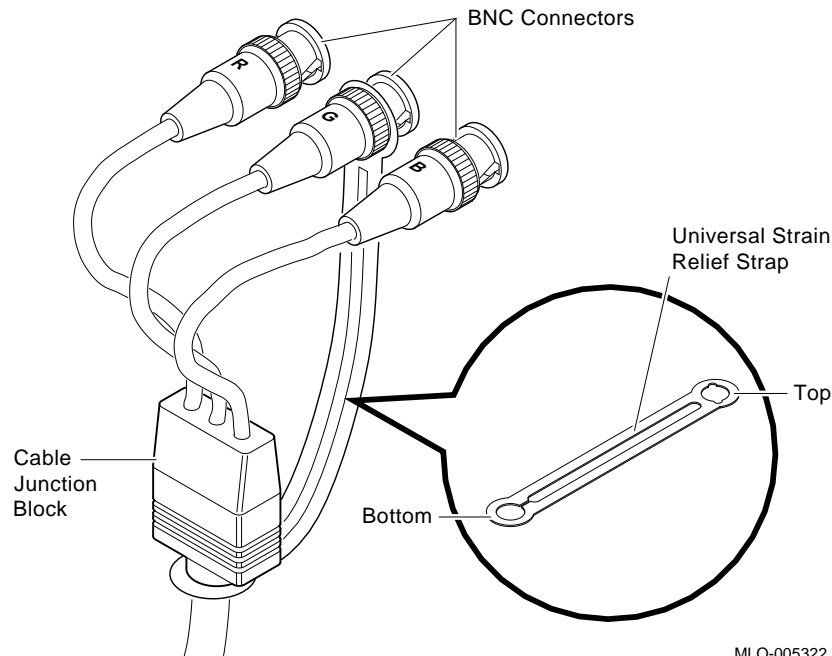

Note

Make sure the strap is under the cable junction box.

- b. Pull the video cable into the slotted hole at the bottom end of the strap. Bring the strap flush with the cable junction box.

Attach Connectors and Other Cables

- c. Align the green (G) BNC connector with the two keyslots of the closed hole at the top end of the strap, and snap the BNC connector into the hole.
- d. Attach the BNC connectors of the monitor video cable to the back of the monitor, as shown in Figure 2-7 and outlined in Table 2-1.

Figure 2-7 Attaching the Monitor Cable to the Monitor

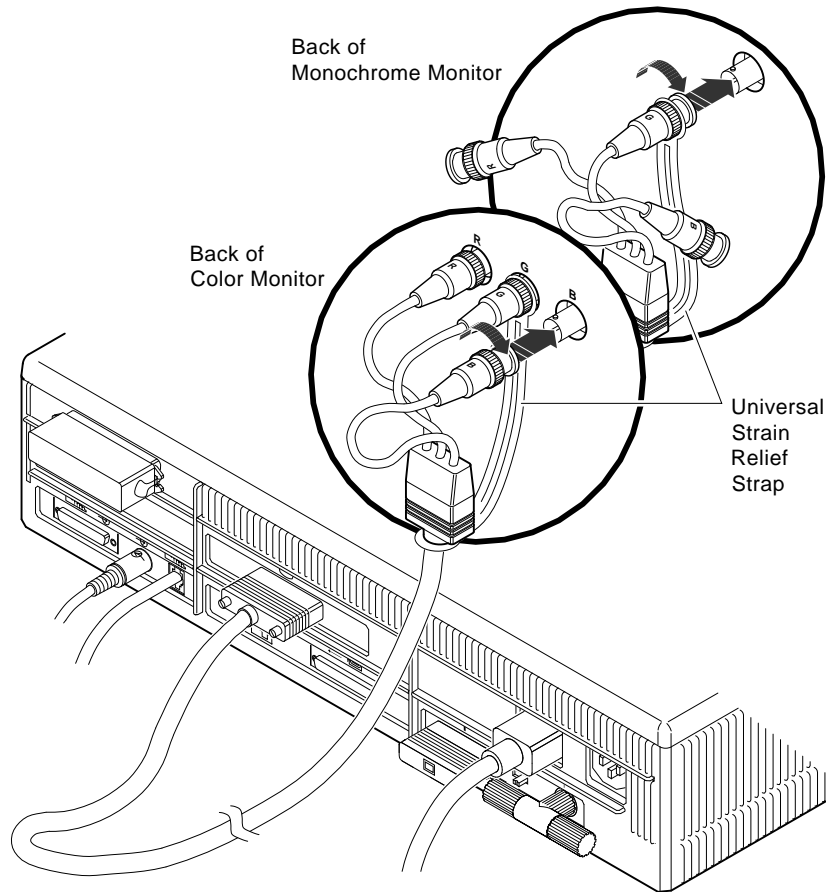

MLO-005326

Table 2-1 Connecting the Monitor Video Cable to the System Unit

If You Have...	Connect the Following
A color monitor	All three cables to the back of the monitor: connect the red cable to the connector on the monitor marked R (for red), the green cable to the connector marked G (for green), and the blue cable to the connector marked B (for blue). Turn all three cables to the right to secure them.
A monochrome monitor	<i>Only</i> the middle cable to the connector on the monitor. Turn the connector to the right to secure it.

Notes

- For all other monitors, connect the video cable as your monitor guide instructs.
 - If your monitor has Video In and Video Out connectors, connect the cable to the Video In connector.
-

Attach Connectors and Other Cables

4. Attach the other end of the monitor power cord to the back of the monitor, as shown in Figure 2–8.

Figure 2–8 Attaching the Monitor Power Cord

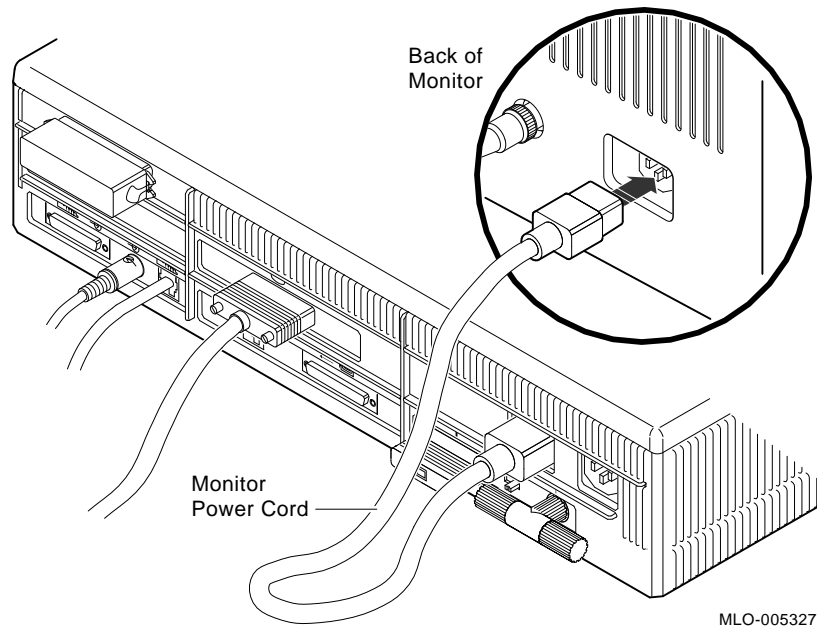

Note

Make sure the power switch on the front of the system is off.

Attach Connectors and Other Cables

5. Attach the system power cord to the back of the system unit, as shown in Figure 2-9.

Figure 2-9 Attaching the System Power Cord

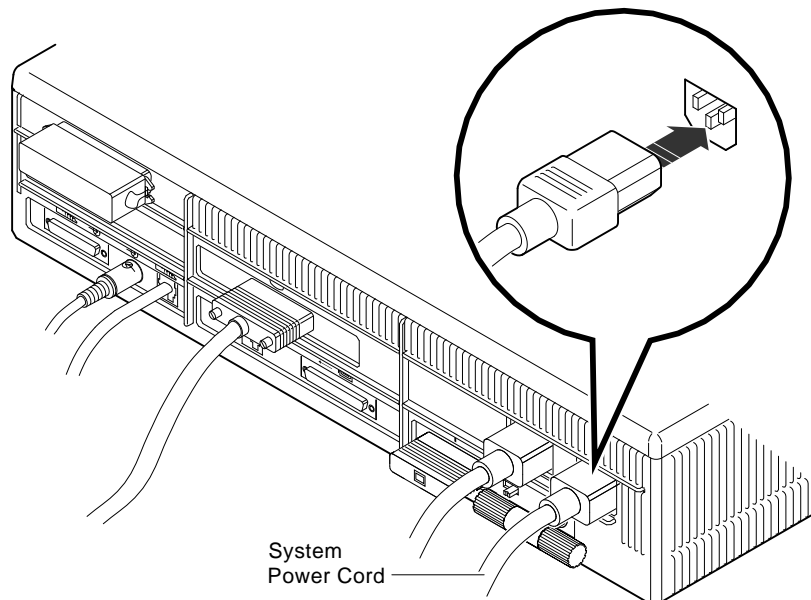

MLO-005315

Note

A yellow sticker covering the power cord connection on the back of the system unit indicates that your system comes with VMS factory-installed software. Remove the sticker, shown in Figure 2-10, before you plug the cord into the system. See *Starting from a Disk* for more information on factory-installed software.

Figure 2–10 VMS Factory-Installed Software Sticker

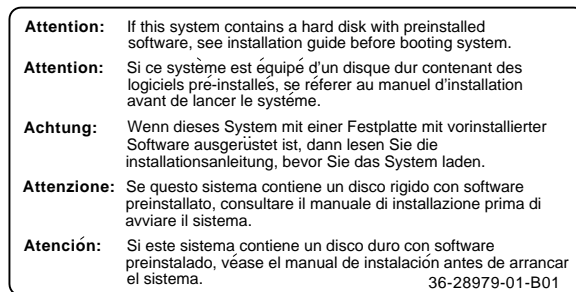

MLO-007063

6. Plug the other end of the system power cord into a power outlet.

Before turning on the monitor, see your monitor installation guide for details on installation procedures and monitor features. Then return here to turn on your system.

If you have an expansion box, refer to the *BA46 Storage Expansion Box Owner's Guide* or the *SZ03 Storage Expansion Box Owner's Card* and then return here.

Turn on (|) the System Unit

Turn on (|) the System Unit



Press the on/off switch to the on (|) position, as shown in Figure 2–11.

Figure 2–11 On/Off Switch

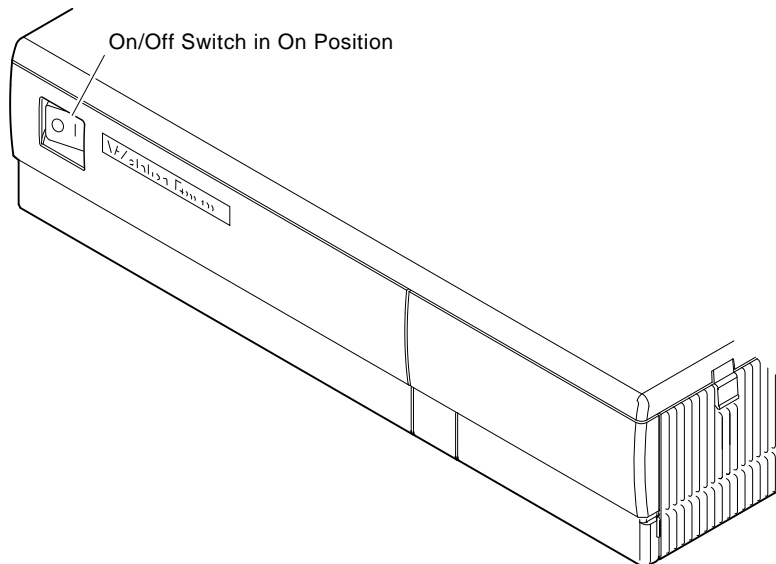

MLO-005137

You should hear a series of beeps, which lets you know that the system is being tested.

Check the Automatic Test Display on the Screen

Check the Automatic Test Display on the Screen

As each test completes, the status bar fills. The more memory you have, the longer the test takes, up to a few minutes. When all tests have completed without errors, the status bar is filled completely, as shown in Figure 2-12.

Figure 2-12 Successful Automatic Test Display

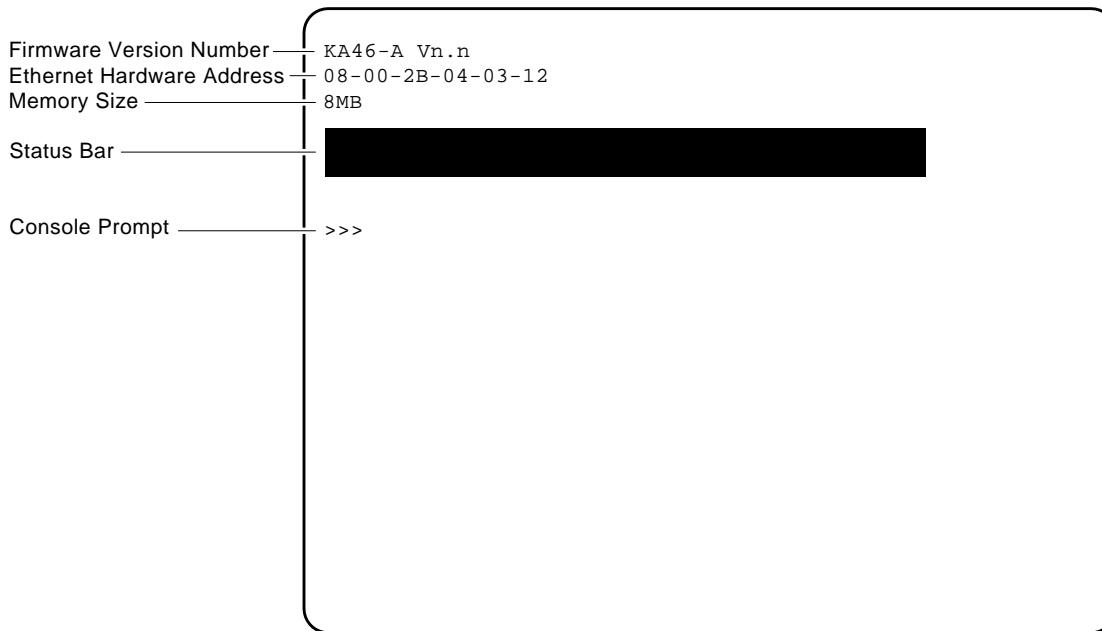

MLO-005316

Note

The firmware version number for the Model 60 is KA46-A Vn.n, where n stands for the firmware version on your system.

Check the Automatic Test Display on the Screen

If one of the tests fails, the status bar does not fill completely and an error line is displayed, followed by ?84 FAIL, as shown in Figure 2-13.

Figure 2-13 Test Display with Error Message

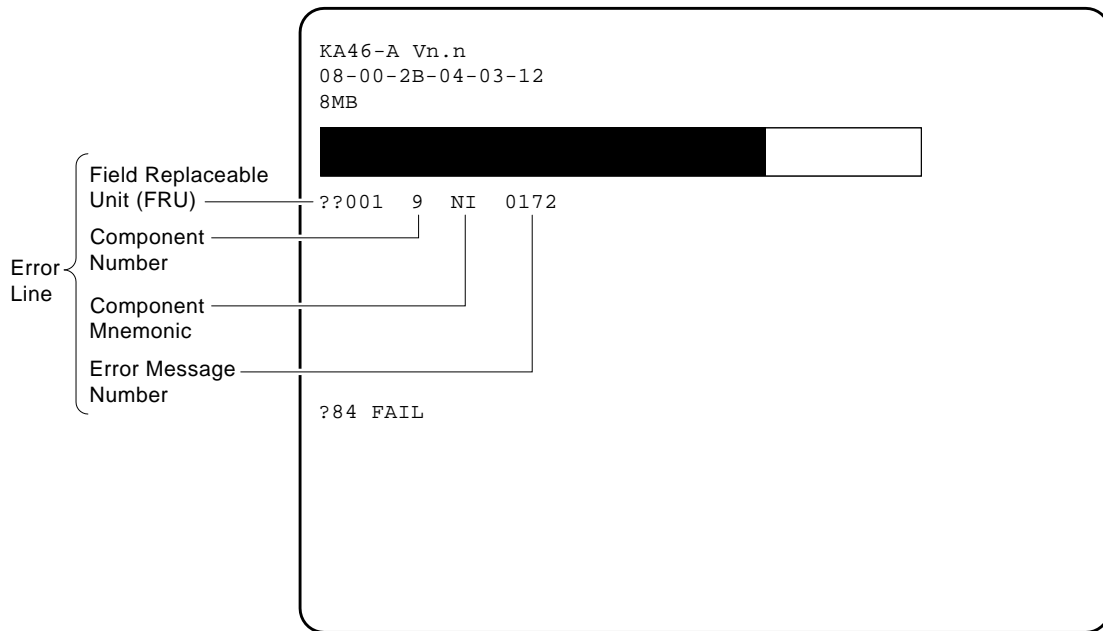

MLO-005317

Refer to Appendix G for an explanation of error messages.

Before you call your Digital service representative to report the problem, do the following:

1. Record the error line on the system information form, described in *Keep a Record of System Information* .
2. Turn off (O) the system unit.
3. Check each cable and connector and turn on (I) the power again. Also note whether the status bar fills and record this information on the system information form, described in *Keep a Record of System Information* .



Check the Automatic Test Display on the Screen

4. Check to see if the problem re-occurs. If so, refer to Using the Troubleshooting Table for troubleshooting information or contact your Digital service representative, as described in Reporting Problems to Your Digital Service Representative .



After the status bar successfully fills, open the door on the front of the system unit and press the Halt button, as shown in Figure 2-14. This puts the system in console mode, displaying the console prompt (>>>) and allowing you to enter commands.

Figure 2-14 Halt Button

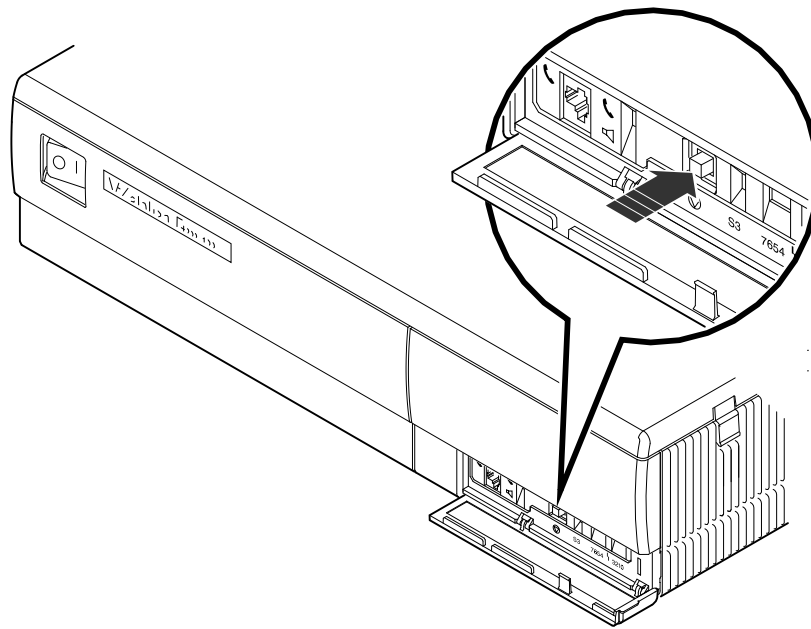

MLO-005094

Other Steps for Using Your Workstation

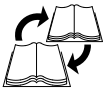

Your basic workstation hardware is now installed. If you want to do further tasks, refer to the table below. If you have an internal fixed disk drive, turn on your system to start the factory-installed software.

Table 2–2 lists further tasks and where to find their descriptions.

Table 2–2 Further Tasks

To Do This . . .	Refer To . . .
Connect optional equipment to your system	<i>VAXstation 4000 Options Installation Guide.</i>
Connect your system to a network	Chapter 4 in this guide.
Use the workstation	Chapter 3 in this guide.
Use the VMS operating system	The VMS software documentation kit. (For information on how to order VMS documentation, see Appendix E.)
Learn how to install and use DECwindows	The DECwindows documentation. (For information on how to order DECwindows documentation, see Appendix E.)
Install and use licensed applications	Your application documentation.

If you have the VMS Online Documentation CDROM, you can access information about the VMS operating system and applications using Bookreader.

Keep a Record of System Information

Keep a Record of System Information

Table 2–3 contains information you should record.

Table 2–3 Your System Information

Subject	Example	Where to find it
Status bar filled?	Yes__ No_X_	Enter SHOW CONFIG command and press Return at the console prompt (>>>). (If you have a local printer attached to your workstation, you can press the Print Screen key (F2) for a printed copy of the SHOW CONFIG display.)
Error line	??001 9 NI 0172	Enter SHOW CONFIG command and press Return at the console prompt (>>>).
Date of installation	21-05-91	
Serial number	AB50505760	Behind the door on the front of the system unit.
Model number	VS32V-A3	Behind the door on the front of the system unit.
Ethernet hardware address	08-00-2B-04-03-12	Enter SHOW ETHERNET command and press Return at the console prompt (>>>).
Firmware version number	KA46-A Vn.n	Enter SHOW CONFIG command and press Return at the console prompt (>>>). Then read the first line of the display.
SCSI ID 0	RZ23L	Enter SHOW CONFIG command and press Return at the console prompt (>>>). Then read line 10, under DEVNBR, which lists the SCSI devices connected to your system. See Table B–1 for recommended SCSI IDs for particular devices.
SCSI ID 1	RZ24	As above
SCSI ID 2	RZ25	As above
SCSI ID 3	RZ23L	As above
SCSI ID 4	RRD42	As above
SCSI ID 5	TZK10 or RX26	As above
SCSI ID 6	INITR	As above
SCSI ID 7	(any device)	As above

3

Using Your System

This chapter explains how to use your workstation, including information about:

- Turning Your Workstation On and Off
- Starting from a Disk
- Fixed Disk Drives
- RRD42 Compact Disc Drive
- RX26 Diskette Drive
- TZK10 Tape Drive
- DSW21 Synchronous Communications Adapter
- Moving Your System

Turning Your Workstation On and Off



To turn on your workstation:

1. Turn on (|) your equipment in the following order:
 - Monitor
 - Printer and modem, if you have these
 - Storage expansion boxes, if you have the BA46 or the SZ03 Storage Expansion Box
 - System unit
2. Adjust the brightness and contrast on your monitor, as follows:
 - Turn both brightness and contrast to the lowest setting so you see almost nothing on your screen.
 - Turn the brightness up until you see the image area at the left and right edges of the screen.
 - Turn the brightness back down just until the image area disappears.
 - Set the contrast to the level most comfortable for you.

For more information, refer to your monitor documentation.

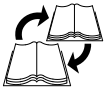

To turn off your workstation:

1. Halt the system by pressing the halt button behind the door on the front of the system unit.
2. Turn off the system and peripheral devices.

Note

Before halting or turning off your system, see the operating system documentation for shutdown procedures. If your system is part of a networked work group, do not turn off, halt, or restart the system without notifying work group members.

Turning Your Workstation On and Off



3. Turn off (O) the equipment in the following order:

- System unit
- Expansion boxes
- All peripheral devices such as printers and modems
- Monitor

Note

If the monitor power cord is plugged into the system unit, turn off (O) the monitor with the monitor on/off switch. The monitor power port on the system unit does not turn off when the system unit is turned off.

Warning

Because the monitor builds up voltage, if you need to unplug the monitor power cord for any reason, you must first turn off the monitor, then wait 3 minutes before unplugging the power cord.

Starting from a Disk

If your workstation has an internal disk drive, you should run the VMS factory-installed software by entering the following command at the console prompt (>>>):

```
>>> B 
```

The VMS factory-installed software asks you to confirm the system time and date and to enter password information. Follow the remaining instructions on the screen.

Adding and Handling Drives

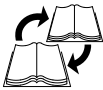

To install drives in your system unit, refer to the *VAXstation 4000 Options Installation Guide*. You can add the following drives:

- RZ23L, RZ24, or RZ25 fixed disk drive
- Compact disk drive (RRD42)
- Diskette drive (RX26)
- Tape drive (TZK10)

Drives are installed inside the system unit behind the front bezel, as shown in Figure 3-1.

Figure 3-1 Location of Additional Drives

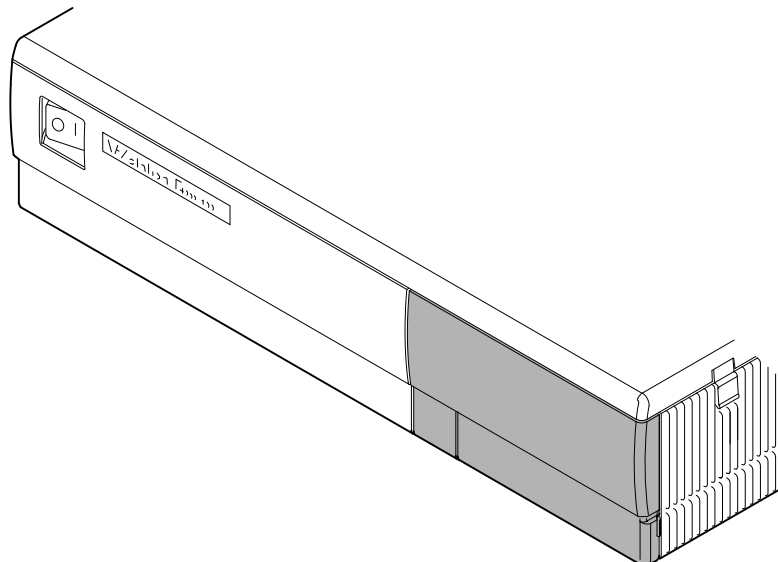

MLO-005894

Fixed Disk Drives

A fixed disk drive allows you to store information on a nonremovable fixed disk. Your system unit can be equipped with one or two 3½-inch fixed disk drives. The following fixed disk drives are available for your system:

- The RZ23L fixed disk drive stores 121 megabytes of information.
(You can store approximately 500 pages or 2000 characters in 1 megabyte of disk space.)
- The RZ24 fixed disk drive stores 209 megabytes of information.
- The RZ25 fixed disk drive stores 426 megabytes of information.

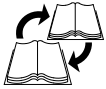

For further information, refer to the *RZ Series Disk Drive Subsystem* documentation.

RRD42 Compact Disc Drive

The RRD42 compact disc drive is a retrieval device that reads data stored on a removable compact disc. A compact disc stores up to 600 megabytes of permanent data; the test disc that is shipped with the RRD42 compact disc drive has a capacity of 199 megabytes. You can use the compact disc drive to install the VMS operating system and other software and to access read-only databases, such as online documentation sets. The drive also has a handset jack that allows the use of headphones for listening to audio information recorded on the compact disc. Figure 3-2 shows the RRD42 compact disc drive controls and indicators.

Figure 3-2 RRD42 Compact Disc Controls and Indicators

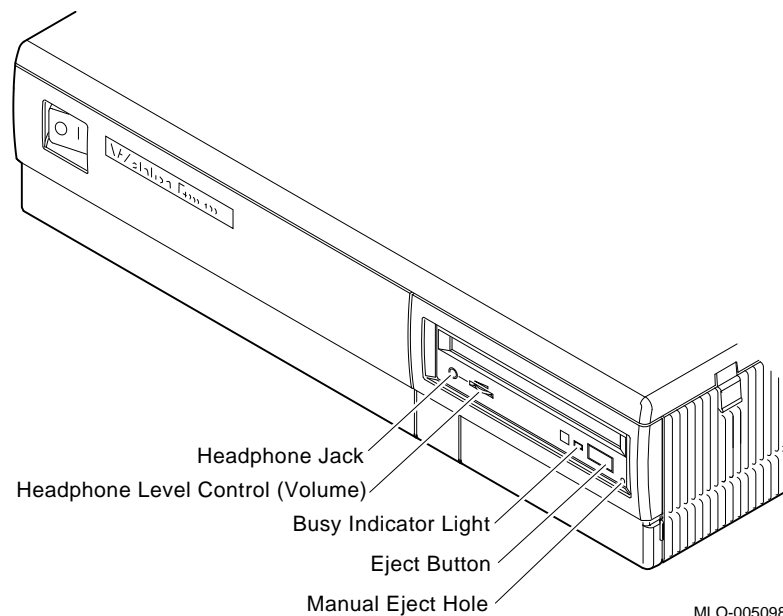

The following sections explain how to use and care for the disc drive.

Handling and Storing Compact Discs

Take the following precautions when handling and storing compact discs and the disc caddies into which discs are loaded:

- Do not drop the disc or the caddy.
- Do not disassemble the caddy; it has been precisely adjusted at the factory.
- Do not touch the surface of a disc; always handle a disc by its edges.
- Never manually open the caddy shutter, shown in Figure 3-3. The caddy shutter opens automatically when you insert the caddy into the drive.

Figure 3-3 Compact Disc Caddy Shutter

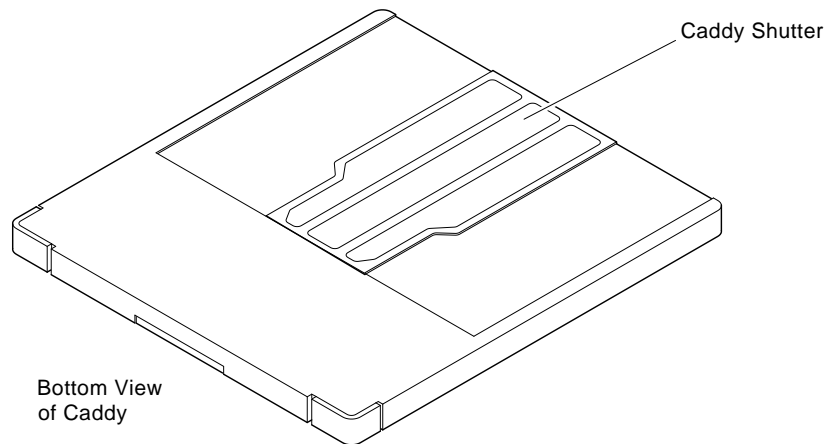

MLO-005164

- Store discs and caddies away from dust.
- Keep discs and caddies out of direct sunlight, and away from heaters and other heat sources.
- Wipe a disc with a lint-free cloth when dust or fingerprints contaminate its surface.

RRD42 Compact Disc Drive

Loading a Compact Disc into a Caddy

To load a compact disc into a caddy:

1. If there is a protective film on the center of the caddy lid, remove the film, as shown in Figure 3–4, before using the caddy.

Figure 3–4 Removing the Protective Film on a Compact Disc Caddy

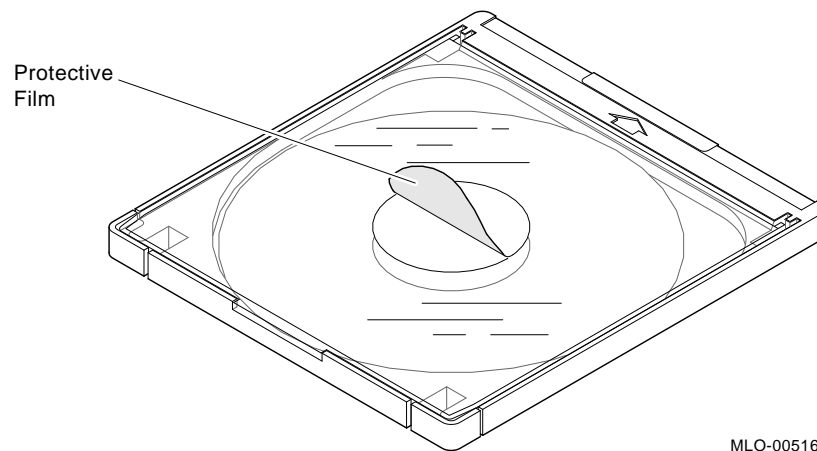

MLO-005161

2. Open the caddy by pressing the tabs on both sides of the caddy at the end opposite the shutter, as shown in Figure 3-5.

Figure 3-5 Opening the Compact Disc Caddy

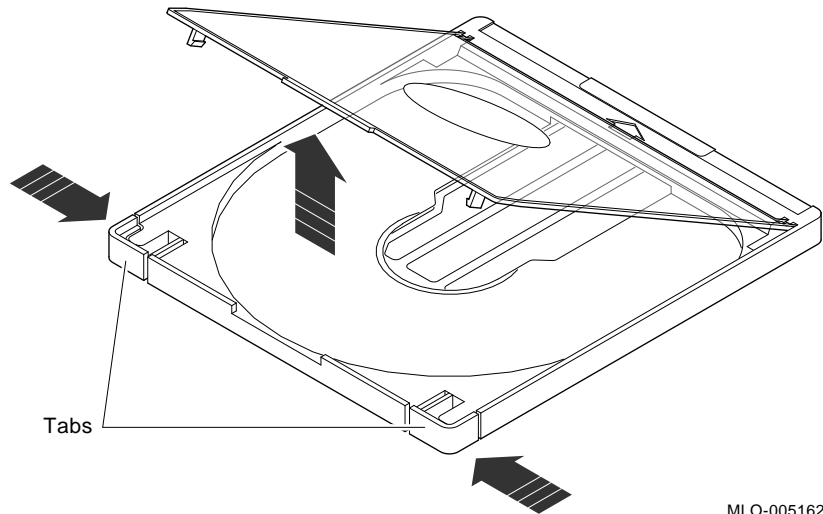

MLO-005162

3. Set a disc, with its printed side up, into the caddy, as shown in Figure 3-6.

Caution

Always handle a disc by its edges; do not touch the surface. If you do get fingerprints and dust on the disc, which can cause it to malfunction, wipe the disc with a lint-free cloth.

Figure 3-6 Loading a Compact Disc into a Caddy

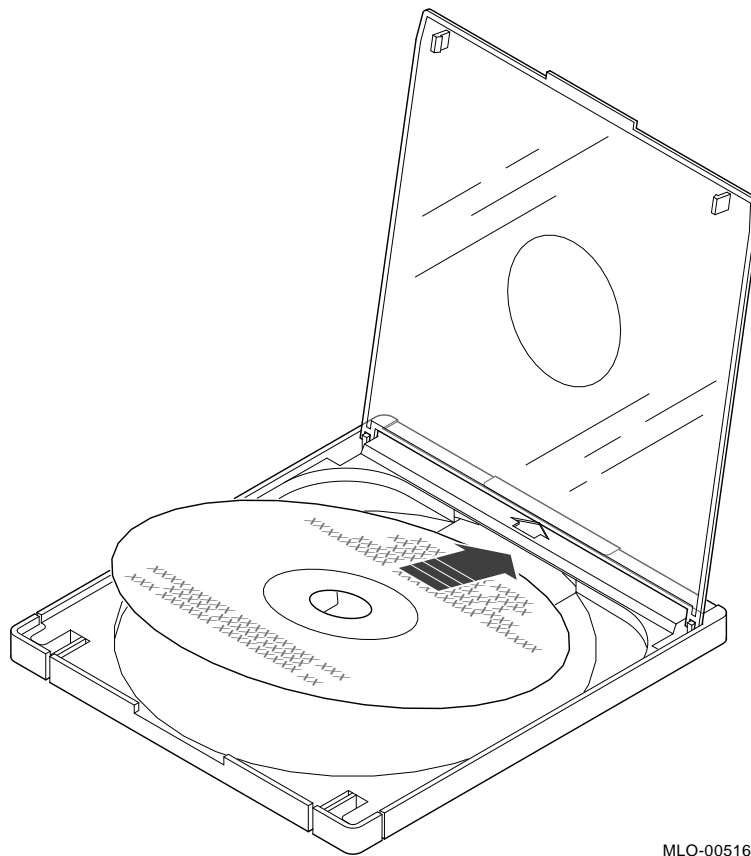

MLO-005163

4. Close the caddy lid by pressing both corners firmly until they snap into place.

Inserting a Loaded Caddy

To insert a loaded compact disc caddy into the drive:

1. Make sure the system unit is turned on (|).
2. Insert the disc caddy into the drive with the arrow label facing up, as shown in Figure 3-7, and the caddy shutter facing down. Push the caddy into the drive as far as it will go. The caddy should be completely within the drive when properly inserted.

Figure 3-7 Inserting a Compact Disc Caddy into the Drive

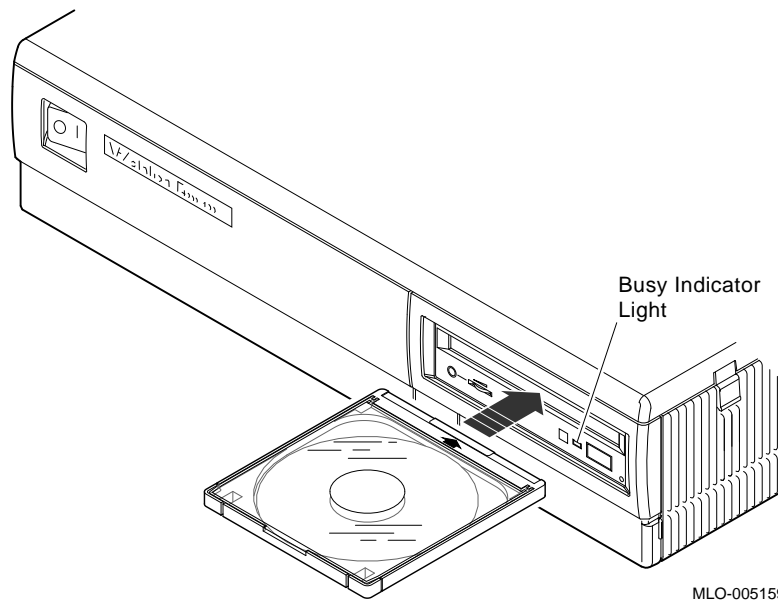

MLO-005159

3. Check the indicator light, which comes on when the caddy has been inserted correctly.
The caddy is ejected if the disc within is upside down, if the disc is improperly positioned in the caddy, or if any other conditions prevent the drive from reading the disc.
4. When the indicator light goes off, the compact disc drive is ready to use. To use the software on the compact disc, follow the instructions provided with your system software.

RRD42 Compact Disc Drive

Removing a Compact Disc Caddy



To remove a compact disc caddy, press the eject button. If the eject button is disabled under the control of the software, you can remove the disc manually, as follows:

1. Turn off (O) the system unit, as described in *Turning Your Workstation On and Off*.
2. Insert a steel rod the size of a large paper clip into the manual eject hole, as shown in Figure 3–8, and push until the disc emerges from the drive.

Figure 3–8 Manually Removing a Compact Disc Caddy

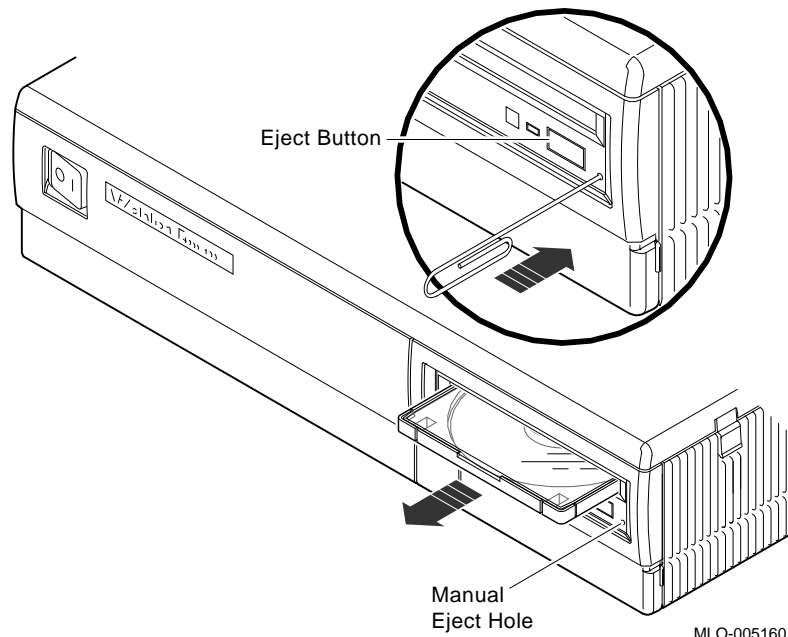

RX26 Diskette Drive

You can use the RX26 diskette drive to increase mass storage and to perform system backup and data interchange. The drive uses industry-standard 3½-inch diskettes. Table 3–1 lists storage capacities for compatible diskettes of various densities.

Table 3–1 Storage Capacity of RX26 Diskettes

Diskette	Unformatted	R/W ¹
Double density (DD)	1.0 MB	R
High density (HD)	2.0 MB	R/W
Extra density (ED)	4.0 MB	R/W

¹R/W = read/write capability

The following sections explain how to use and care for diskettes.

Handling and Storing RX26 Diskettes

Take the following precautions when handling and storing diskettes:

- Keep your diskettes dry, out of extreme temperatures and direct sunlight.
- Keep the diskettes away from any equipment that contains a magnet, such as the monitor or a telephone.

The heat and electromagnetic field of your monitor can damage diskettes by distorting or erasing the magnetic data.

For further information, refer to the *RX26 Owner's Reference Card*.

RX26 Diskette Drive

Figure 3-9 illustrates the controls and indicator lights for an RX26 diskette drive.

Figure 3-9 RX26 Diskette Drive Controls and Indicator Lights

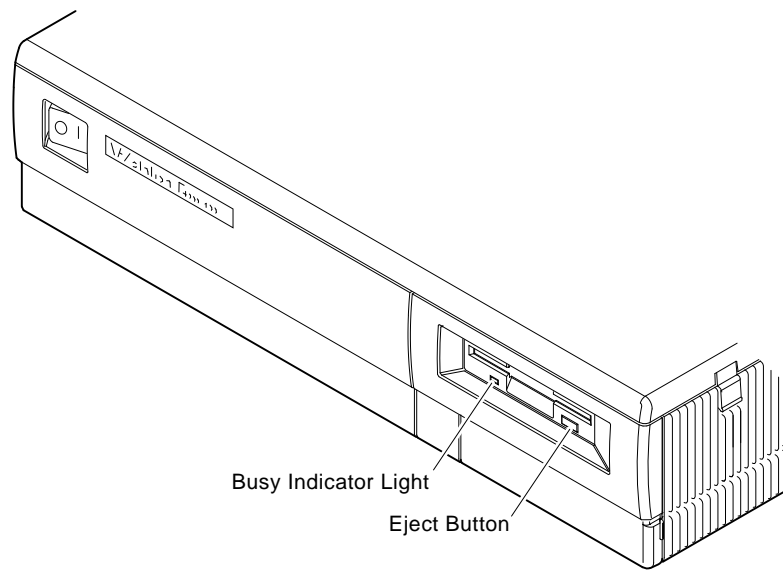

MLO-006006

Write-Protecting Diskettes

Write-protecting a diskette prevents accidental overwriting or erasure of data on the diskette. For example, if you are using a diskette to install software applications on your system, you may want to protect the information on the diskette.

Before you use a diskette, check its write-protect switch. When the switch is in the Protect position, you can read information from the diskette, but cannot write to it.

1. To write-protect a diskette, move the write-protect switch on the back of the diskette down until it locks into place, as shown in Figure 3–10.

Figure 3–10 Write-Protecting a Diskette

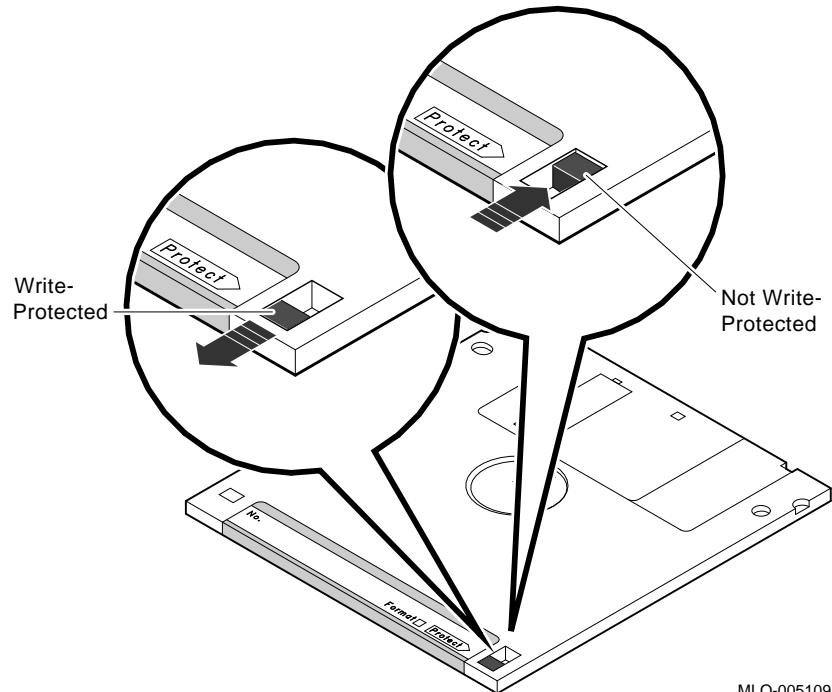

2. To write to a diskette, that is, to allow writing data on the diskette, slide the switch on the back of the diskette up until it locks into place.

RX26 Diskette Drive

Inserting and Removing Diskettes

1. To insert a diskette into the diskette drive, slide the diskette, arrow side up, into the drive, as shown in Figure 3–11. The diskette slides straight in and drops down to its load position.

Figure 3–11 Inserting a Diskette

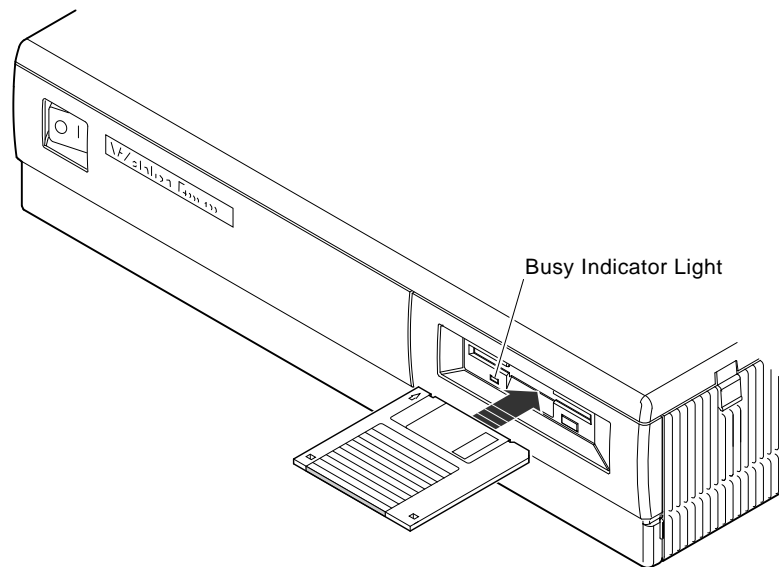

MLO-005092

Caution

Never insert or remove a diskette when the diskette drive is in use (the indicator light—LED—on the front of the drive is on); doing so can damage the diskette.

RX26 Diskette Drive

2. To remove a diskette:
 - a. Dismount the diskette drive by entering the DISMOUNT DKA0: command at the console prompt (>>>).
 - b. Make sure the LED is off.
 - c. Press the eject button, as shown in Figure 3–12. When the diskette pops halfway out, pull down on the door, grasp the diskette, and slide it out of the drive.

Figure 3–12 Removing a Diskette

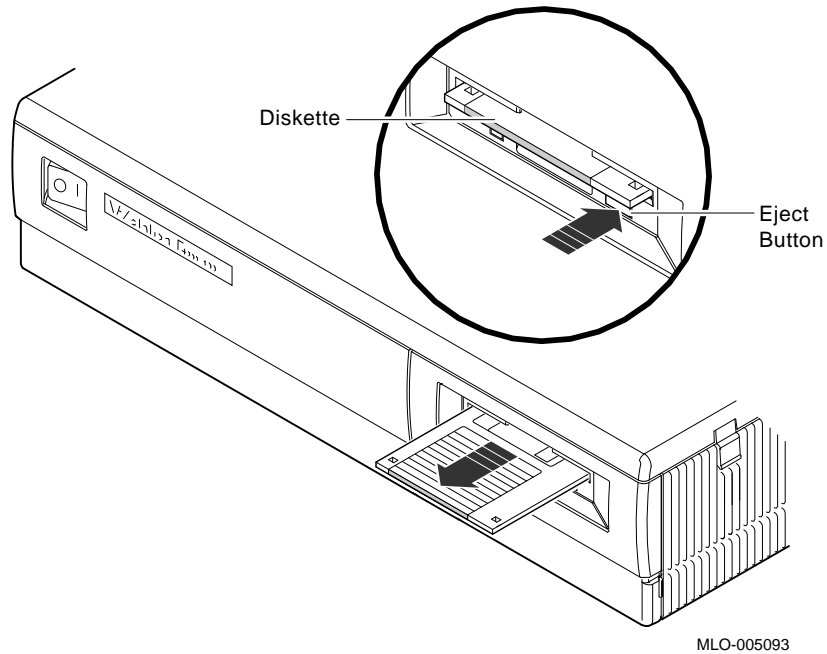

TZK10 Tape Drive

The TZK10 cartridge tape drive is a half-height, 5¼-inch, 525-megabyte, streaming tape drive that uses a standard quarter-inch cartridge (QIC). The TZK10 tape drive provides archival storage and retrieval and data collection capabilities.

The TZK10 tape drive can use any of the Digital tape cartridges listed in Table 3–2. The drive is shipped with a DC6320 tape cartridge.

Table 3–2 TZK10 Tape Cartridges

Cartridge	Capacity	Format	R/W ¹	Length
DC6525	up to 525 MB	QIC-320	R/W	300 m (1000 ft)
DC6320	up to 320 MB	QIC-320	R/W	186 m (620 ft)
DC6150 DC600XTD	up to 150 MB	QIC-150	R/W	189 m (620 ft)
DC6150 DC600XTD	up to 120 MB	QIC-120	R/W	189 m (620 ft)
DC600A	up to 60 MB	QIC-24	R	183 m (600 ft)

¹R/W = read/write capabilities

The following sections explain how to use and care for tape cartridges.

Handling and Storing TZK10 Tape Cartridges

Take the following precautions when handling and storing tape cartridges:

- Avoid dropping or striking cartridges.
- Keep cartridges out of direct sunlight, away from heaters and other sources of heat.
- Store cartridges where the temperature is between 10°C and 40°C (50°F and 104°F).
- If a cartridge has been exposed to extreme heat or cold, allow it to stabilize at room temperature for the same amount of time as it was exposed, up to 24 hours.

- Avoid placing cartridges near sources of electromagnetic interference, such as terminals, motors, and video or X-ray equipment. Any tape exposed to a magnetic field can lose information.
- Store a cartridge in a dust-free environment where the relative humidity is between 20% and 80%.
- Store a cartridge in its protective container, on edge or stacked. However, when stacking cartridges, do not stack more than five high.
- Place an identification label only in the space provided for the label on top of the cartridge.

For further information refer to the *TZK10 Cartridge Tape Drive Owner's Guide*.

Write-Protecting TZK10 Tape Cartridges

The TZK10 tape cartridge has a write-protect switch to prevent accidental overwriting of data. Rotate the switch to the write-protected position, indicated by the word **SAFE** imprinted on the case. (See Figure 3–13). If you are writing data to the tape, turn the write-protect switch away from the **SAFE** label.

Figure 3-13 Write-Protecting TZK10 Tape Cartridges

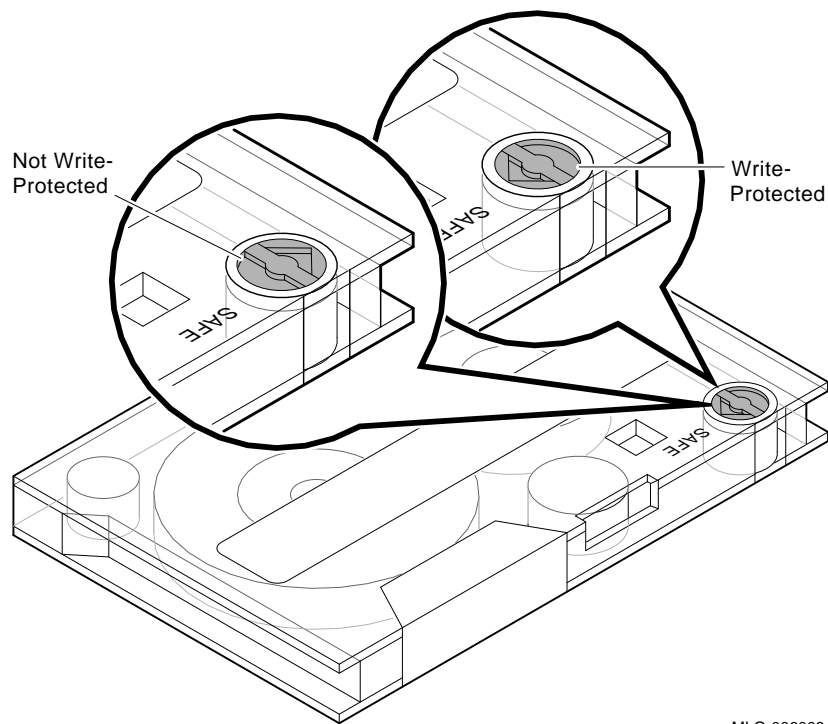

MLO-006008

TZK10 Controls and Indicator Lights

The TZK10 cartridge tape drive, shown in Figure 3–14, has one dual-color (green and amber) busy indicator light and an eject button.

Figure 3–14 TZK10 Controls and Indicators

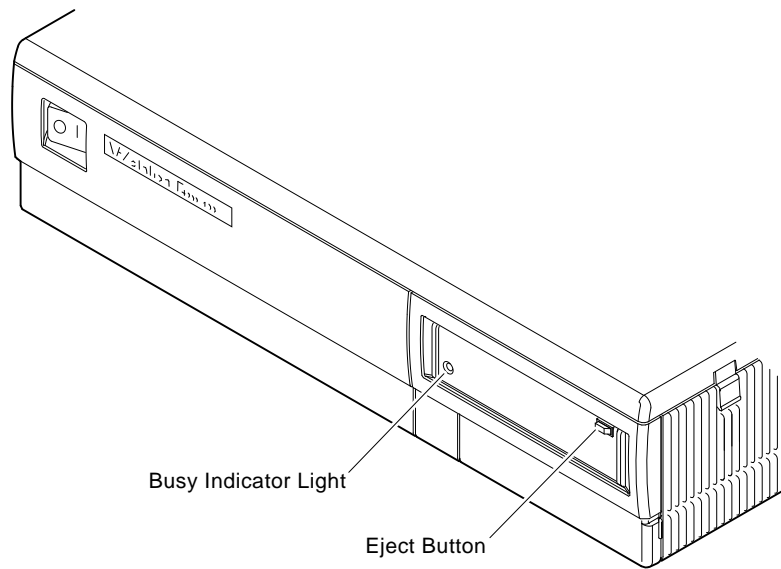

MLO-006004

Table 3–3 summarizes the meaning of each state of the busy indicator light.

Table 3–3 TZK10 Indicator Light States

State	Meaning
Off	Tape is not present or tape is present but is not loaded (is dismounted.)
Solid green	Tape is loaded (mounted). ¹
Blinking green	Tape is in motion.
Solid amber	Drive is faulty.

¹Tape cartridge is auto-loaded upon insertion.

TZK10 Tape Drive

Inserting a TZK10 Tape Cartridge

To insert the TZK10 tape drive:

1. Make sure the system unit is on (|).
2. Press the eject button to open the drive door on the front of the system unit (see Figure 3–15).
3. Insert the TZK10 tape cartridge into the drive with the cartridge's write-protect switch in the upper right corner.
(Be sure the write-protect switch is set to the correct position.)
4. Slide the cartridge straight into the drive until you feel resistance, then close the door.

When the tape is properly inserted, the indicator light is solid green and you can issue operating system commands.

Figure 3–15 Inserting the TZK10 Tape Cartridge

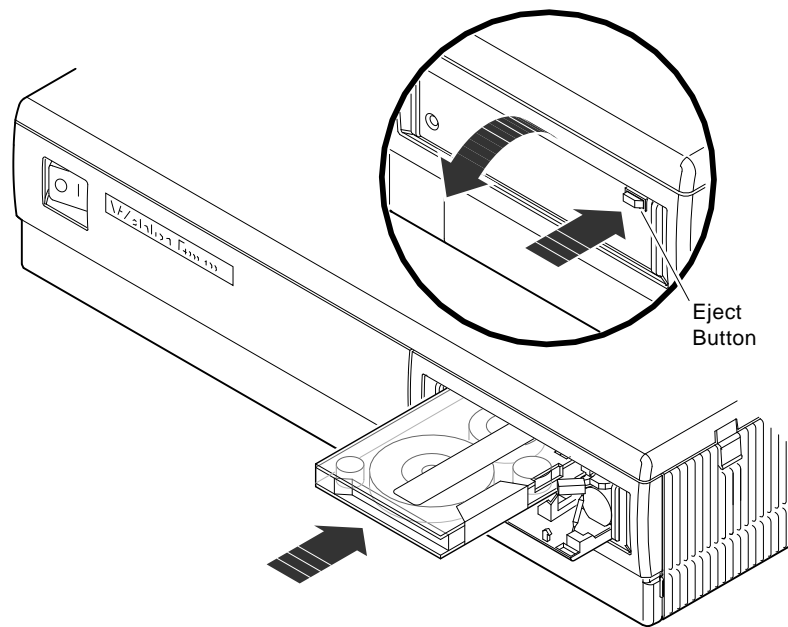

MLO-006005

Removing a TZK10 Tape Cartridge

While data is being transferred, the indicator light is blinking green. After data transfer is complete, the tape stops and the indicator light returns to solid green. To remove the tape cartridge, press the eject button, as shown in Figure 3–16. The door opens and the cartridge ejects part way. Pull down on the door, grasp the cartridge, and slide it out of the drive.

Figure 3–16 Removing the TZK10 Tape Cartridge

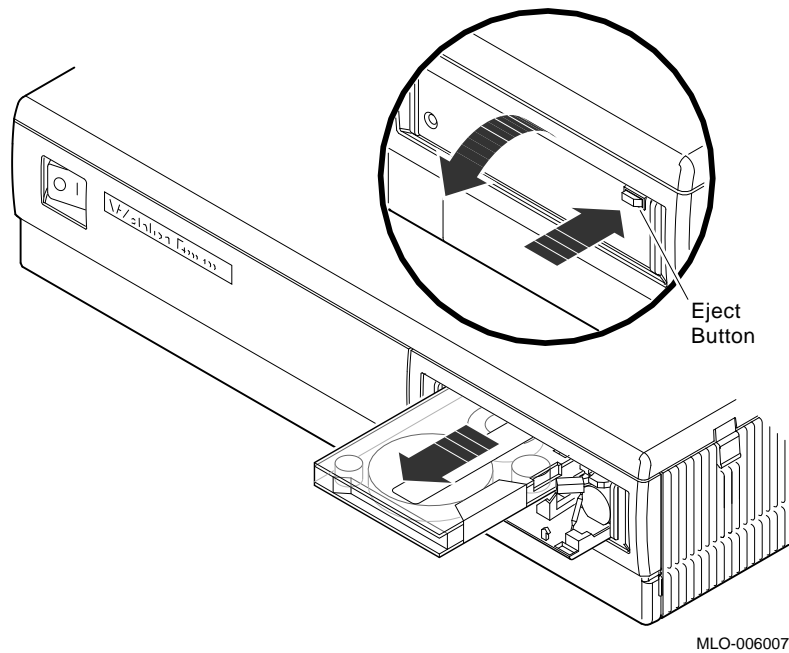

DSW21 Synchronous Communications Adapter

The DSW21 Synchronous Communications Adapter is an optional synchronous serial interface, also referred to as the COMM board. The adapter hardware is supported by the wide area network device driver (WANDD), which communicates with software applications, such as DECnet. The WANDD must be ordered separately through your Digital sales representative.

Table 3-4 lists the hardware associated with the DSW21 Synchronous Communications Adapter.

DSW21 Synchronous Communications Adapter

Table 3-4 Hardware Associated with the DSW21 Synchronous Communications Adapter

I/O Adapter Cable	Part Number	Number of Pins	Type of Cable	EIA Standards	CCITT Standards
BC19Q-02	17-03091-01	25	Straight	EIA-530	
BC19U-02	17-01871-01	37	Straight	EIA-449/422	V.11/V.36
BC19V-02	17-01872-01	25	Straight	EIA-232-D	V.24
BC19W-02	17-01873-01	37	Straight	EIA-449 /423	V.10
BC19X-02	17-01874-01	34	Straight		V.35
BC20Q-02	17-03097-01	15	Straight		BT kilostream
BC22F-25	17-00323-00	25	Extension cable	EIA-232	V.24
BC55D-25	17-00372-00	37	Extension cable	EIA-449 /422, /423	V.10, V.11/V.36
Test Connectors					
H3198	12-26259-01	37		EIA-449 /422, /423	
H3198	12-26259-01	37		EIA-449 /422, /423	
H3199	12-25852-01	50	DEC multistandard Total Loopback /423		
H3248		25		EIA-232	V.24
H3250		34			V.35

Moving Your System

Take the following steps to repack the system to move it to another location:



1. Shut down the operating system.

Note

See the operating system documentation for shutdown procedures. If your system is part of a networked work group, do not turn off, halt, or restart the system without notifying work group members.

2. Halt the system by pressing the halt button behind the door on the front of the system unit.
3. Turn off the system unit.
4. Turn off (O) the equipment in the following order:
 - System unit
 - Expansion boxes
 - All peripheral devices such as printers and modems
 - Monitor

Note

If the monitor power cord is plugged into the system unit, turn off (O) the monitor with the monitor on/off switch. The monitor power port on the system unit does not turn off when the system unit is turned off.

Warning

Internal voltage remains for a short while after the monitor is turned off. To avoid a minor injury, wait for several minutes before touching metal parts of the monitor, or ground the monitor before you move it.



Moving Your System

5. Label all cables and cords connected to the system unit as you disconnect them.
6. If you saved cartons and packaging material when you first unpacked the system, reuse that material to pack the equipment for the move.
7. If you did not save the original packing material, be sure the equipment is packed securely in heavy boxes and/or wrapped in material that will prevent breakage.
8. Check all the power outlets in the new location for correct wiring, voltage, and grounding before plugging in any devices or the system unit.

After you move the system, connect all device cables to the system unit before connecting any device or the system unit to the power outlets.

4

Connecting Your System Hardware to a Network

This chapter explains the following:

- Testing Your Ethernet Subsystem
- Connecting to an Ethernet Network
- Troubleshooting the Network Connections
- Removing a System from ThinWire Ethernet

All networking cables and connectors must be purchased separately and must be available before network connection.

Testing Your Ethernet Subsystem

Before connecting to a network, you need to verify that the Ethernet subsystem (the Ethernet controller chip on the system board) is operating properly. To test your system's Ethernet subsystem, follow these steps:



1. Make sure that the T-connector with two terminators is connected to the ThinWire Ethernet port on the back of the system unit.



2. Make sure that the Ethernet loopback connector is securely connected to the standard Ethernet port on the back of the system unit.



3. Turn on (|) your system (see [Turning Your Workstation On and Off](#)). The light on the back of the Ethernet loopback connector should come on. The power-up display, shown in [Figure 4-1](#), appears on the screen:

Figure 4–1 Successful Power-Up Display

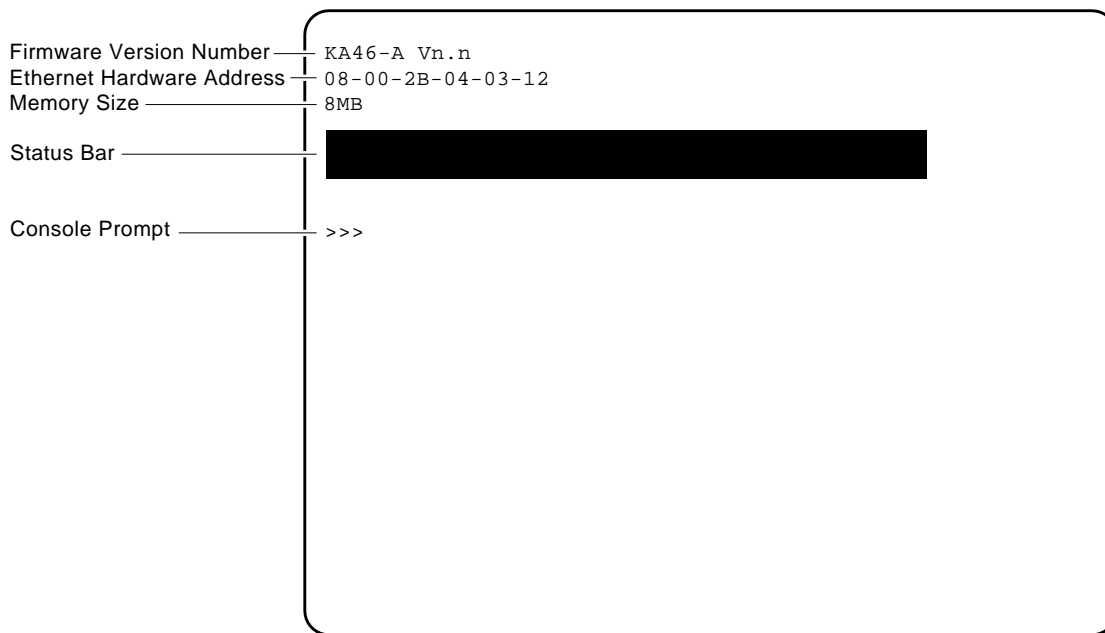

MLO-005316

Note

If the console prompt (>>>) does not appear on the monitor screen, press the halt button on the front of the system unit.



4. Write down your Ethernet hardware address from the second line of the power-up display (Figure 4–1) on the blank network label that comes with your system.

Testing Your Ethernet Subsystem

5. Your network manager will give you a unique node name for your system and a unique node address for DECnet. Write these on the network label also.

You will need the Ethernet hardware address and node name for system identification during software installation and VAXcluster configuration.

6. Open the door on the front of the system unit and install the network label, as shown in Figure 4-2.
(Save the extra labels for future use in case your node name or address changes.)

Figure 4-2 Attaching the Network Label

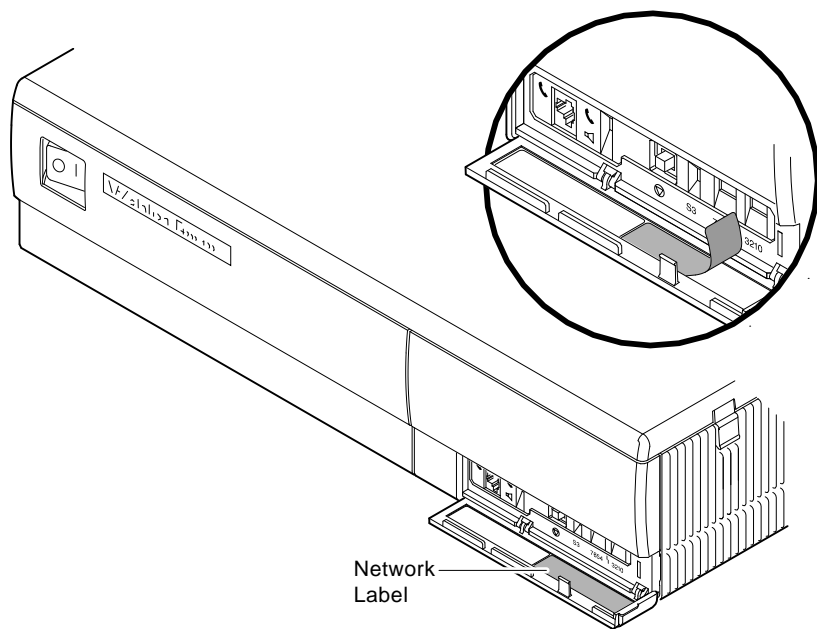

MLO-005474

Testing Your Ethernet Subsystem

7. Enter the following command at the console prompt:

```
>>> SHOW CONFIG 
```

If you see the message OK next to the mnemonic NI (number 9), as shown in Figure 4–3, the system’s Ethernet subsystem is working and you have completed verification.

Figure 4–3 SHOW CONFIG Display

```
>>> SHOW CONFIG
Firmware Version Number KA46-A Vn.n
Ethernet Hardware Address 08-00-2B-0A-7D-CB
Memory Size 8MB
Column Headings DEVNBR  DEVNAM  INFO
-----
      1      NVR      OK
      2      LCG      OK
Graphics Line      LR-MONO FB-1.0
      3      DZ      OK
      4      CACHE  OK
      5      MEM      OK
Memory Line      8MB = SY=8MB, S0/1=0MB, S2/3=0MB, S4/5=0MB
      6      FPU      OK
      7      IT      OK
Informational      8      SYS      OK
Message           9      NI      OK
SCSI Line        10     SCSI     OK
                0-RZ23L  5-RZ24  6-INITR
      11     AUD      OK
      12     COMM     OK
>>>
```

MLO-005446

Reading the SHOW CONFIG Display

The SHOW CONFIG display tells you if the system components are installed properly.

The following list explains each line of the display in Figure 4–3.

- The firmware version number for the Model 60 is KA46-A Vn.n, where n stands for the firmware version on your system.
- The Ethernet hardware address, 08-00-2B-0A-7D-CB, is the number needed for connecting a system to a network.
- The memory size indicates the size of memory in megabytes.
- The column headings indicate the component number (DEVNBR), the component name (DEVNAM), and the status of each system component (INFO).
- The graphics line, LR-MONO FB-1.0 (low-resolution monochrome), shows the type of graphics board in the system unit. The 1.0 in this line means that this board is version 1.0 of the frame buffer. See Table 4–1 for an explanation of other mnemonics on the LCG (low-cost graphics) line.

Table 4–1 LCG Graphics Board Mnemonics for the SHOW CONFIG Command

Mnemonic	Meaning
LR	Low resolution
HR	High resolution
MHHR	Dual screen high resolution
FB	Frame buffer
MONO	Monochrome
4PLN	4-plane

- The memory line displays the total number of megabytes on the system board and on the 6 additional memory slots. The memory line is further explained as follows:
 - SY—megabytes on system board
 - S0/1—megabytes in memory slots 0 and 1

Testing Your Ethernet Subsystem

- S2/3—megabytes in memory slots 2 and 3
- S4/5—megabytes in memory slots 4 and 5
- The informational message indicates whether there is a problem with the component or device.
- The SCSI line displays status information, the SCSI ID number, and the mnemonic for the SCSI device.

If a message other than OK is displayed next to the mnemonic NI, as in Figure 4–4, there may be a failure in the Ethernet subsystem.

Figure 4–4 SHOW CONFIG Display with Error

```
>>> SHOW CONFIG
KA46-A Vn.n
08-00-2B-0A-7D-CB
8MB
DEVNBR  DEVNAM  INFO
-----  -
 1      NVR      OK
 2      LCG      OK
          LR-MONO FB-1.0
 3      DZ       OK
 4      CACHE   OK
 5      MEM      OK
          8MB = SY=8MB, S0/1=0MB, S2/3=0MB, S4/5=0MB
 6      FPU      OK
 7      IT       OK
 8      SYS      OK
 9      NI       ?? 001 0172
10      SCSI     OK
          0-RZ23L 5-RZ24 6-INITR
11      AUD      OK
12      COMM     OK
>>>
```

Error Indicator — 8

FRU of Failed Device — 9

Error Number — 11

MLO-005447

Testing Your Ethernet Subsystem

In this figure, the error line contains three values in the INFO column:

- The error indicator is a pair of question marks (??) in the column next to the mnemonic of the faulty device or system component.
- The field replaceable unit (FRU) number identifies the failed device or component. In this example, the failed FRU number (001) identifies the system board (the Ethernet subsystem resides on the system board).
- The error number indicates a specific device failure. In this example, the error number (0172) means that there is no Ethernet loopback connector on the system. (For a list of the most common error messages, see Appendix G.) This is a common error that you can easily fix by doing the following:



1. Turn off (O) the system, as described in Turning Your Workstation On and Off .
2. Add the Ethernet loopback connector, or the T-connector, depending on the switch position.
3. Recheck all other Ethernet connections.
4. Turn on (I) the system.
5. Test the Ethernet subsystem with the following command:

```
>>> TEST NI 
```

If this test is successful, a short solid status bar is displayed on the screen.

If this test fails, there is an internal hardware problem, the connection is not made, and an error line is displayed.

If you continue to receive a failure indicator, make a note of the error line and contact your Digital service representative, as described in Chapter 5.

Connecting to an Ethernet Network

To connect your system to an Ethernet network, complete the following tasks:



1. Put the system in console mode (>>>) by pressing the Halt button behind the door on the front of the system. Console mode allows you to test all devices and components.



2. Turn off (O) the system unit, as described in Turning Your Workstation On and Off .



3. Check the network switch shown in Figure 4–5.

Figure 4–5 Network Switch

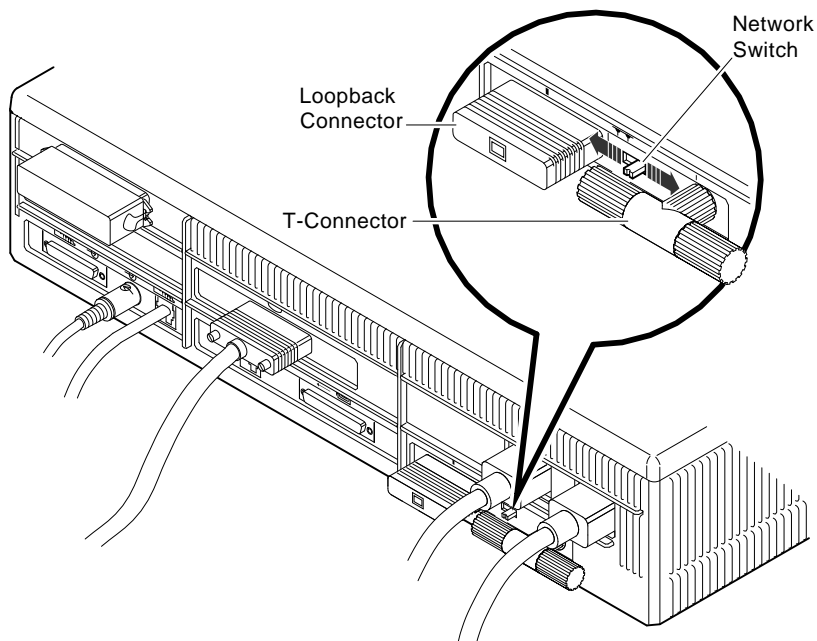

MLO-005318



- To connect to a standard Ethernet network, move the network switch left, toward the loopback connector.
- To connect to a ThinWire Ethernet network, move the switch right, toward the T-connector.

Connecting to an Ethernet Network

4. If you are connecting to a ThinWire Ethernet network, perform the following steps:
 - a. Remove the T-connector from the system unit.
 - b. Remove one or both terminators from the T-connector.
 - c. Add the ThinWire cable to the T-connector in place of the terminators, as shown in Figure 4–6.

Note

If your workstation is the last one on the ThinWire cable, you need to leave one terminator on to terminate the network connection.

Figure 4–6 Adding ThinWire Cable

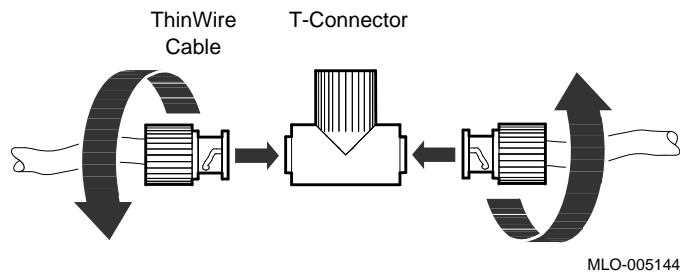

Connecting to an Ethernet Network

- d. Reconnect the T-connector to the ThinWire Ethernet port on the back of the system unit, as shown in Figure 4–7.

Figure 4–7 Connecting ThinWire Cable to ThinWire Port

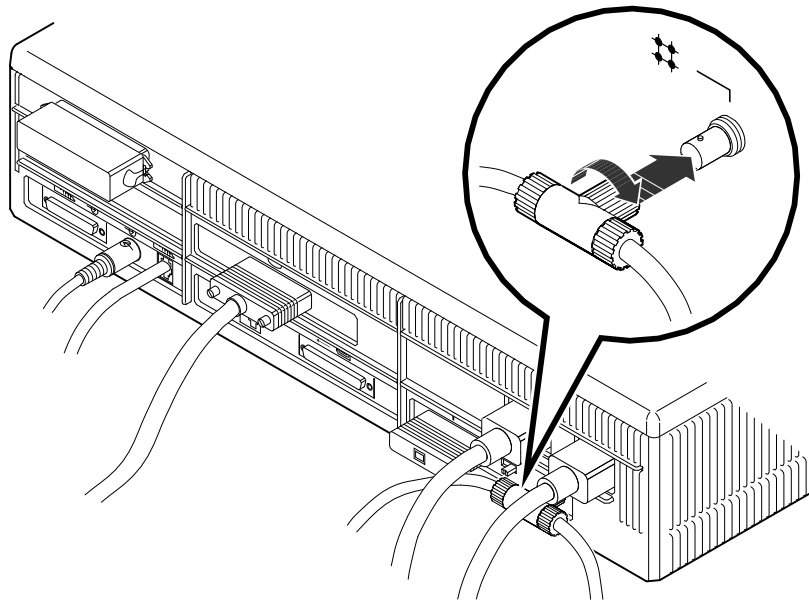

MLO-005319

5. If you are connecting to a standard Ethernet network, perform the following steps:
 - a. Remove the Ethernet loopback connector and store it for future diagnostic testing.

Connecting to an Ethernet Network

- b. Connect the standard Ethernet cable to the standard Ethernet port on the back of the system unit, as shown in Figure 4-8.

Figure 4-8 Connecting Standard Ethernet Cable to Standard Ethernet Port

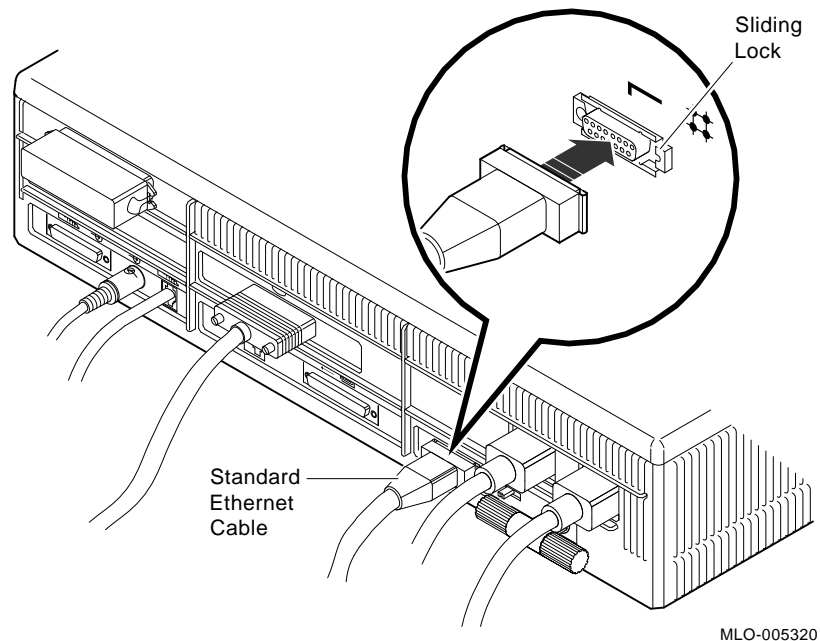

- c. Move the sliding lock on the standard Ethernet port to the left to secure the connection.

Connecting to an Ethernet Network

6. If you are creating a work group, consult with your network manager.

A work group is created by serially connecting several workstations together on the same ThinWire Ethernet cable segment. A segment is a length of cable made up of one or more cable sections connected with barrel connectors or T-connectors. This cable segment can function as a standalone network or it can be connected to a larger network.

Figure 4-9 shows a server connected to several satellites, forming a work group.

Figure 4-9 VAXstation Systems in a Work Group

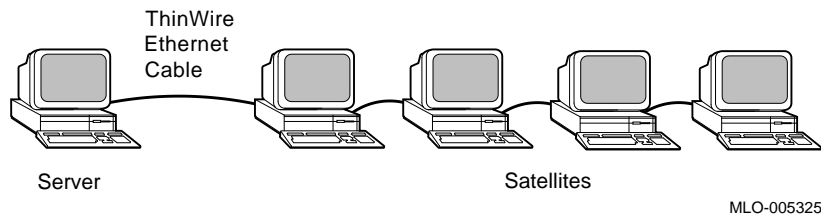

Connecting to an Ethernet Network

7. If your office is wired with Digital DECconnect products, connect your system to a DECconnect faceplate as follows:
 - a. Attach one end of the ThinWire Ethernet cable to the DECconnect faceplate.
 - b. Check that the T-connector at the other end of the ThinWire cable is firmly attached to the ThinWire port on the back of your system unit. Figure 4–10 shows a system plugged into a DECconnect office faceplate.

Figure 4–10 DECconnect Faceplate

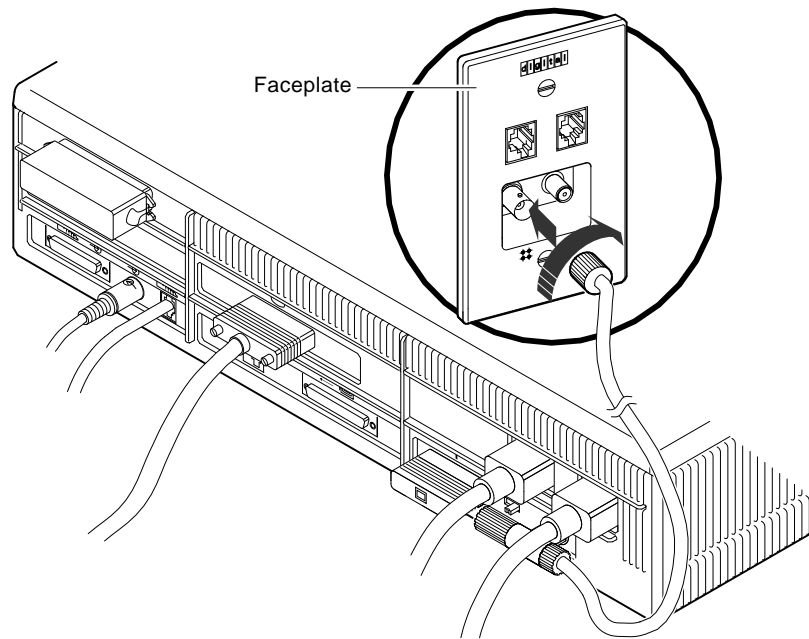

MLO-005448

8. Turn on (|) your system, as described in Turning Your Workstation On and Off .
9. Verify all Ethernet cable connections by entering the following command at the console prompt:

```
>>> TEST NI 
```

Troubleshooting the Network Connections

If you are connected to an Ethernet network and are having problems, refer to the appropriate checklist:



ThinWire Ethernet Checklist

Make sure:

1. The network switch is pushed toward the ThinWire port.
2. The T-connector has not been disconnected from an operating ThinWire Ethernet segment.
3. You have not disconnected a terminator from either end of an active ThinWire segment. This action disrupts network operation.
4. All connections on the ThinWire Ethernet segment are secure.



Standard Ethernet Checklist

Make sure:

1. The standard Ethernet cable is securely connected to the system and that the sliding lock is secure.
2. The network switch is pushed toward the standard Ethernet port.



Then retest the network by entering the TEST NI command.

Removing a System from ThinWire Ethernet

If you need to remove a workstation from ThinWire Ethernet, consult your network coordinator.



1. Turn off (O) the system unit, as described in Turning Your Workstation On and Off .

Note

Before halting or turning off your system, see the operating system documentation for shutdown procedures. If your system is part of a networked work group, do not turn off, halt, or restart the system without notifying work group members.

Removing a System from ThinWire Ethernet

2. Disconnect the center of the T-connector directly from the back of the system unit. Figure 4–11 shows the correct way to remove a T-connector from an inactive ThinWire segment.

Figure 4–11 Removing a System from an Inactive ThinWire Segment

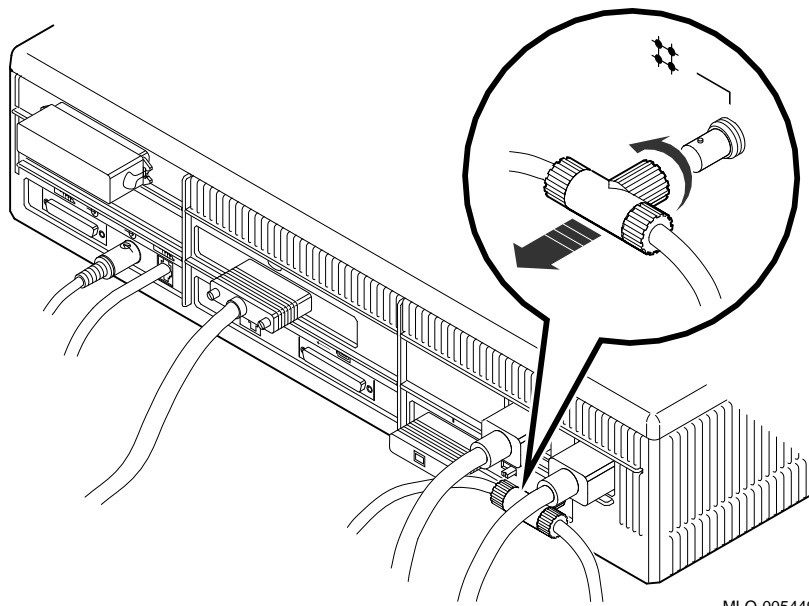

MLO-005449

5

Handling Problems

This chapter explains:

- Identifying a Problem
- Using the Troubleshooting Table
- Reporting Problems to Your Digital Service Representative

If you know the source of your problem, see *Using the Troubleshooting Table* for suggested solutions. Otherwise, begin with *Identifying a Problem* .

Identifying a Problem

To determine where your problem is, follow these steps:

1. Refer to your operating system documentation for shutdown procedures *before* turning off your system and peripheral devices.

Caution

Failure to meet this requirement may cause loss of user data or system failure.



2. Turn off (O) the system unit.
3. Turn off (O) all expansion boxes and all peripheral devices such as printers and modems.
4. Turn off (O) the monitor.

Note

If the monitor power cord is connected to the system unit, turn off (O) the monitor using the monitor on/off switch. The auxiliary outlet on the system unit does not turn off when the system unit is turned off.

5. Check that the following cables are correctly connected at both ends:
 - Monitor video cable
 - Monitor power cord
 - System unit power cord
 - Expansion box connector cable
 - Expansion box power cord
 - Keyboard cable (the end at the system unit only)
 - Mouse/tablet cable (the end at the system unit only)
 - Network cables

At this point, all equipment should be turned off.



6. Turn the equipment back on (|) in the following order:
 - Monitor
 - Printer
 - Storage expansion box
 - System unit
7. Adjust the brightness and contrast on your monitor.

If you still have a problem, refer to Using the Troubleshooting Table .

Using the Troubleshooting Table

Determine the source of your problem, and then follow these steps:

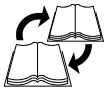

- For problems with the storage expansion box, see the *BA46 Storage Expansion Box Owner's Guide*, which comes with the BA46 expansion box or the *SZ03 Storage Expansion Box Owner's Card*, which comes with the SZ03 Storage Expansion Box.
- For other problems:
 1. Note the symptoms of the problem.
 2. Check the Symptom column in Table 5–1 for a match.
 3. Check the conditions for that symptom in the Possible Cause column in Table 5–1. If more than one possible cause is given, check the possible causes and their suggested solutions in the order listed.
 4. Follow the advice in the Suggested Solution column in Table 5–1.
 5. Run the system exerciser, as described in Testing All Components Simultaneously .
 6. If the problem persists, call your Digital service representative, as described in Reporting Problems to Your Digital Service Representative .

Using the Troubleshooting Table

Table 5–1 Troubleshooting

Symptom	Possible Cause	Suggested Solution
System Unit Problems		
System unit fan is off and the power light is off.	Power cord is not connected.	Check the power cord connections at both ends.
	Wall outlet may not be working.	Try a different outlet or try an electrical device that you know works in that outlet. If the problem persists, contact your Digital service representative, described in Reporting Problems to Your Digital Service Representative .
	Power cord is faulty.	Replace the power cord.
Power-up display contains an error message.	Power supply or fan has failed.	Contact your Digital service representative.
	A module or internal cable may not be properly installed, or may be defective.	If an error message appears in the power-up display, see Sections Identifying Faulty Components , Identifying the Problem , and Testing All Components Simultaneously for further test instructions. Check the seating of modules and cables depending on the fault indicated by the error message.
Window display does not appear on the screen. (System does not boot.)	Your software is not installed.	See your software documentation for installation instructions.
	Video option has failed.	See Sections Identifying the Problem and Testing All Components Simultaneously for more information.
	Default recovery action is set to halt.	Change the default recovery action to boot the system from the system disk. See Appendix A.
	Incorrect boot device was specified.	Change the default recovery action to boot the system from the system disk. See Appendix A.
	Software problem.	Call your Digital service representative.

(continued on next page)

Using the Troubleshooting Table

Table 5–1 (Cont.) Troubleshooting

Symptom	Possible Cause	Suggested Solution
Monitor Problems		
Power-up display does not appear after 2 minutes.	Monitor is not turned on.	Check the monitor on/off switch; be sure it is on. (1)
	Power cord is not connected.	Check that the monitor power cord is connected at both ends.
	Monitor cable or video cable is not connected.	Check that the monitor cable and video cable are connected at both ends.
	Monitor brightness and contrast controls are set too low for the screen display to be seen.	Adjust the monitor brightness and contrast controls. If necessary, refer to your monitor guide for more information.
	Alternate console switch is in the wrong position.	Turn off the power. Change the alternate console switch to the down (off) position. Use a small pointed object to set the switch, but do not use a pencil; the graphite will damage the switch. See Using an Alternate Console with Your System for more information. Turn the power back on.
	Monitor fuse is blown.	See your monitor guide for fuse replacement instructions.
	Wall socket may not be working.	Try a different wall socket, or try an electrical device that you know works in the wall socket. If the problem persists, contact your Digital service representative.
	Color monitor is installed, but the color graphics board is not installed.	Install the color graphics board. If the problem persists, contact your Digital service representative.

(continued on next page)

Using the Troubleshooting Table

Table 5–1 (Cont.) Troubleshooting

Symptom	Possible Cause	Suggested Solution
Monitor Problems		
	System did not pass power-up test.	Check the diagnostic lights. Contact your Digital service representative and report the light pattern.
	Monitor is defective.	Contact your Digital service representative.
Mouse/Tablet Problems		
Mouse or optional tablet pointer does not appear on screen, or monitor does not respond to pointing device commands.	CTRL F3 was pressed by mistake, and system pointer mode is off.	Press CTRL F3 again to restart the pointer mode.
	Pointing device cable is installed incorrectly or is loose.	Turn off the system. Disconnect and then reconnect the cable to reset the device.
	The system is in console mode; no pointer appears on the screen.	Change the system to program mode by entering BOOT at the console prompt (>>>). (See Rebooting the System After Testing).
	Pointing device is faulty.	Replace the pointing device, or call your Digital service representative.
Keyboard Problems		
Keys do not work.	Hold Screen key is active (the Hold Screen light is on).	Press the Hold Screen key to release the hold on the screen.
	Keyboard cable is loose or not connected.	Check the keyboard cable connection to the system unit.
	Keyboard has failed.	Replace the keyboard. If the problem persists, contact your Digital service representative.

(continued on next page)

Table 5–1 (Cont.) Troubleshooting

Symptom	Possible Cause	Suggested Solution
SCSI Device Problems		
An installed drive does not work.	Two SCSI identifiers are set to the same number.	Type SHOW DEVICE. If a drive is not recognized, reset each SCSI ID to a unique number. (See Appendix B.) For example, the RRD42 compact disk drive has a SCSI ID of 4.
For other SCSI device problems, refer to the <i>BA46 Storage Expansion Box Owner's Guide</i> that comes with your BA46 storage expansion box or the <i>SZ03 Storage Expansion Box Owner's Card</i> that comes with your SZ03 Storage Expansion Box.		
Disk and Diskette Problems		
Software does not boot from the RZ23L or RZ24 fixed disk drive.	A problem exists with the fixed disk.	See Sections Confirming Option Installation and Testing All Components Simultaneously .
	Default boot device is set incorrectly.	See Appendix A to set or change the default boot device.
	Recovery action may be set to halt.	See Appendix A to change the default recovery action.
	A problem exists with the software (if installed) on the fixed disk.	Refer to your software documentation for help.
	Two SCSI identifiers are set to the same number.	Reset each SCSI ID to a unique number. (See Appendix B.)
Software installed in the diskette drive does not work, or a diskette read or write error message is displayed.	No diskette is in the diskette drive.	Insert a software diskette. Use the instructions in your software documentation.
	Diskette was inserted incorrectly.	Check that the write-protect notch on the diskette is to your left when you insert the diskette and that the label is up.

(continued on next page)

Using the Troubleshooting Table

Table 5–1 (Cont.) Troubleshooting

Symptom	Possible Cause	Suggested Solution
Disk and Diskette Problems		
	Diskette is damaged or does not contain software.	Try another diskette that contains software.
	Two SCSI identifiers are set to the same number.	Reset each SCSI ID to a unique number. (See Appendix B.)

Symptom	Possible Cause	Suggested Solution
Network Problems¹		
NI error message is displayed when testing Ethernet	Network switch is not set properly.	Check that the network switch is in the correct position, left for standard Ethernet, and right for ThinWire Ethernet. If you are not using Ethernet, move the network switch to the left, toward standard Ethernet.
	No ThinWire or standard Ethernet terminator or cable was installed.	Attach a ThinWire or standard Ethernet terminator, or replace the terminator with an active network cable.
	Terminator is missing from network.	If you remove a ThinWire cable, replace it with a terminator and retest the Ethernet.
	Cable connection is loose.	Check that all connections on the Ethernet segment are secure.
Lights 7, 4, 3, and 0 on the front of the system unit are on (see Figure 5–1).	T-connector is disconnected.	Check the T-connector. Make sure that the T-connector is not disconnected from an operating ThinWire Ethernet segment.

¹After you solve an NI problem, type **TEST NI** and press the Return key. This either clears the error or displays a message to let you know the problem still exists.

(continued on next page)

Table 5–1 (Cont.) Troubleshooting

Symptom	Possible Cause	Suggested Solution
TZK10 Tape Problems		
The amber indicator light is on.	Faulty tape cartridge or drive.	Replace the cartridge to determine if the problem is with the cartridge or the drive.
The amber light goes out when you remove the cartridge.	Media problem.	Replace the cartridge.
There's a cartridge error during cartridge insertion.	Cartridge is damaged. Internal portions of the drive are not working.	Try another cartridge or replace the drive.
Audio Problems		
No audio tone (beep) sounds when the system is turned on.	Audio speaker is not working.	Turn off the system. Connect the handset and turn on the system. If you hear an audio tone from the handset only, then there is a problem with the speaker. Contact your Digital service representative. If you do not hear any audio tone from the handset, replace the handset. If the problem persists, contact your Digital service representative.

Reporting Problems to Your Digital Service Representative

If you followed the corrective actions described in this chapter yet continue to have problems with your system, call your Digital service representative, as follows:

1. Before you call, write down the serial and model numbers of your system to give to your Digital service representative. You will find these numbers behind the door on the front of the system unit or on the rear panel of the system unit.
2. Make notes based on Table 5–1. This information helps your Digital service representative know the state of your system when the problem occurred.
3. Be prepared to read information from the screen and to enter commands at the keyboard while you talk to your Digital service representative.
4. Your Digital service representative may ask you which lights are on. Eight recessed diagnostic (LED) lights on the front of the system unit come on when you turn on the system, as shown in Figure 5–1. Write down the status of these lights.



Reporting Problems to Your Digital Service Representative

Figure 5-1 Diagnostic Lights

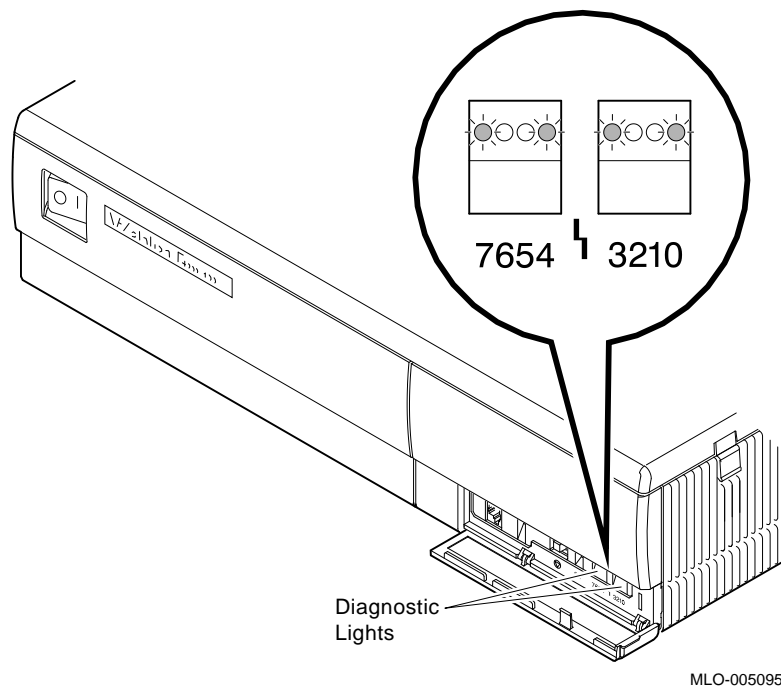

MLO-005095

In Figure 5-1, diagnostic lights 7, 4, 3, and 0 are on. This means that the ThinWire terminator is not properly connected. This is a common error. Check that the ThinWire terminators on either end of the T-connector are firmly connected to the ThinWire Ethernet port when you turn on your system.

Reporting Problems to Your Digital Service Representative

Table 5–2 lists other common errors for which you may need to know the status of the diagnostic lights.

Table 5–2 Diagnostic Light Patterns of Common Problems

Diagnostic Light Pattern	Meaning
OOXO OOOX ¹	The LCG video RAM (random access memory) failed
OOXO OOXO	The LCG register test failed
OOXO OOXX	The LCG FIFO test failed
OOXO OXOO	The LCG interrupt test failed
OOXO OXOX	The LCG address generator test failed
OOXO OXXO	The LCG virtual test failed
OOXX OXOX	The LK401 test failed
OOXX OXXO	The mouse test failed
OXOX OOOX	A memory error occurred during the forward pass for the memory test, that is, while the memory test was moving from address 0 to memsize

¹In these patterns, X=on and O=off. The left-most half of the pattern identifies the device number. The right-most half of the pattern identifies the subtest number.

6

Testing Your System

This chapter explains:

- Identifying Faulty Components Using the Power-up Test
- Identifying the Problem Using the Self Test
- Reporting the Problem to your Digital Sales Representative
- Confirming Option Installation Using the System Exerciser
- Rebooting the System After Testing

Identifying Faulty Components

Every time you turn on your system, it runs power-up tests that display important information. (See Chapter 2). These tests check each component in your system and display a status bar on the monitor screen. When the status bar fills completely, you know the tests finished successfully.

The diagnostic lights on the front of the system unit also indicate the status of the system as it is powering up. After the power is turned on but before any instructions are entered, the lights are all on. After all tests have run successfully, all lights are off.

Note

If your monitor screen does not display any information, you may have a monitor, video, or system board failure or a loose connection. Check Table 5–1 for solutions to monitor problems, then check your monitor guide for more information.

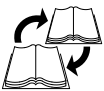

The sample display in Figure 6–1 shows the elements in a power-up error message that identify a failed device or system component.

Table 6–1 Component Numbers and Mnemonics in Power-Up and Self-Tests

Component Number	Component Mnemonic	Component
1	NVR	Nonvolatile random access memory (RAM)
2	LCG	Low-cost graphics coprocessor
3	DZ	Serial line controller
4	CACHE	High-speed memory
5	MEM	Memory
6	FPU	Floating point unit
7	IT	Interval timer
8	SYS	Miscellaneous system board hardware
9	NI	Network interface
10	SCSI	SCSI controller
11	AUD	Sound chip
12	COMM	Communications device
13–99		Reserved for future components

Identifying the Problem

This section describes how to run self-tests on system components or devices installed on your system or in the storage expansion box. To see a list of tests that are available, type **HELP**. Self-test diagnostic programs reside permanently in the system read-only memory (ROM).

To test a particular device or component in your system, follow these steps:

1. Use Table 6–1 to find the number or mnemonic for the device or component you want to test.



2. Put the system in console mode (>>>) by pressing the halt button behind the door on the front of the system unit.

Note

Before halting or turning off your system, see the operating system documentation for shutdown procedures. If your system is part of a networked work group, do not turn off, halt, or restart the system without notifying work group members.

3. Enter TEST followed by a space and either the number or mnemonic of the device or component to be tested; then press the Return key. For example, to test nonvolatile random access memory (RAM), enter:

```
>>> TEST NVR 
or
>>> TEST 1 
```

At first, the system displays an unfilled status bar for the device or component. As the test runs, the status bar fills. If the self-test is successful, the status bar fills completely and the console prompt is displayed.

If you want to test a consecutive series of devices or components, enter TEST followed by the first and last numbers or mnemonics of the series separated by a colon, and press the Return key. For example, to test the first five components listed in Table 6–1, enter:

```
>>> TEST NVR:MEM 
or
>>> TEST 1:5 
```

A single long empty bar is displayed, which fills in as each test is run.

If a device or component fails the self-test, an error message line and the message ?84 FAIL are displayed with the console prompt.

Identifying the Problem

If you change the system configuration, test all devices and components by entering one of the following commands:

```
>>>TEST 1:11  
or  
>>>TEST NVR:AUD
```

Reporting the Problem

See Table 6–2 to identify the field replaceable unit (FRU). Then call your Digital service representative.

Table 6–2 Field Replaceable Unit Numbers and Definitions

FRU Number	Definition
001	System board
002	Keyboard
003	Mouse
004	Monitor #1
005	Monitor #2
010–019	Reserved for graphics boards where graphics board #1 is FRU 010, board #2 is 011, and so forth.
020–029	Reserved for COMM boards where COMM board #1 is FRU 020, board #2 is 021, and so forth.
030–039	Reserved for bus adapters where bus adapter #1 is FRU 030, adapter #2 is 031, and so forth.
040–049	Reserved for memory SIMMS where memory SIMM #1 is FRU 040, SIMM #2 is 041, and so forth.
100–199	Reserved for SCSI controller
400–499	Reserved for future use

Confirming Option Installation

It is a good idea to use the `SHOW CONFIG` or the `SHOW DEVICE` command to confirm that you have installed an optional component or device correctly. In the `SHOW CONFIG` display:

- If new SCSI devices are correctly installed, the message `OK` appears next to the mnemonic `SCSI`, followed by a list of the installed devices.
- If other devices, such as the `DSW21 Synchronous Communications Adapter` or graphics board, are installed correctly, the message `OK` appears next to their mnemonics.

Check Table 6–1 for the mnemonics and their meanings.

Using the `SHOW CONFIG` Command

The configuration display shows the results of the self-tests and power-up tests in a table that lists the status of each device or component. Each time a self-test is run, the configuration display is updated.

To view the status of the current configuration:

1. Put the system in console mode by pressing the halt button behind the door on the front of the system.

Note

Before halting or turning off your system, see the operating system documentation for shutdown procedures. If your system is part of a networked group, do not turn off, halt, or restart the system without notifying work group members.

2. Enter the `SHOW CONFIG` command at the console prompt (`>>>`). A screen such as the one shown in Figure 6–2 is displayed.



Confirming Option Installation

Figure 6-2 SHOW CONFIG Display

```
>>> SHOW CONFIG
Firmware Version Number KA46-A Vn.n
Ethernet Hardware Address 08-00-2B-0A-7D-CB
Memory Size 8MB
Column Headings DEVNBR  DEVNAM  INFO
-----
1      NVR      OK
2      LCG      OK
Graphics Line LR-MONO FB-1.0
3      DZ      OK
4      CACHE   OK
5      MEM      OK
Memory Line 8MB = SY=8MB, S0/1=0MB, S2/3=0MB, S4/5=0MB
6      FPU      OK
7      IT      OK
Informational 8      SYS      OK
Message      9      NI      OK
SCSI Line    10     SCSI    OK
            0-RZ23L  5-RZ24  6-INITR
11     AUD      OK
12     COMM     OK
>>>
```

MLO-005446

Confirming Option Installation

Using the SHOW DEVICE Command

Use the `SHOW DEVICE` command to display a list of the devices installed on your system and their locations on the SCSI bus, as shown in Figure 6–3.

Figure 6–3 SHOW DEVICE Display

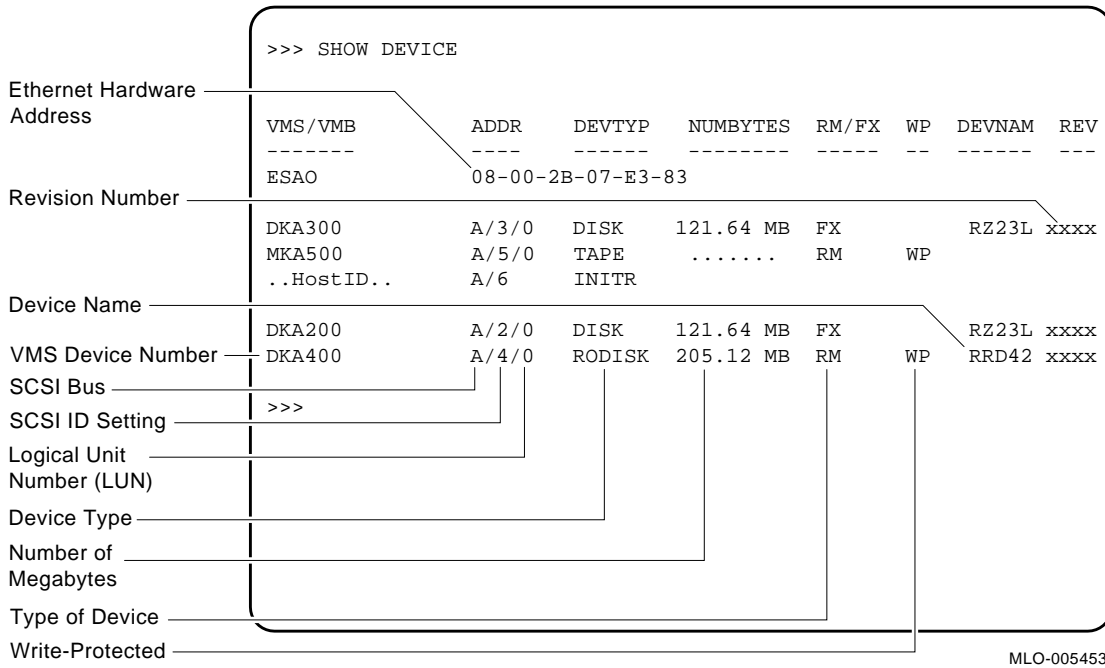

Confirming Option Installation

Table 6–3 explains the column headings in the SHOW DEVICE display.

Table 6–3 Meaning of SHOW DEVICE Display

Column Heading	Definition
VMS/VMB	VMS name for device or component
ADDR	Ethernet hardware address: the number required to set up a system for networking
DEVTYP	Device type
NUMBYTES	Number of megabytes the corresponding device is using
RM/FX	Removable or fixed media device
WP	Write-protected
DEVNAM	Name of device or component
REV	Firmware revision number

Confirming Option Installation

For example, consider the following line from the previous display:

```
DKA400    A/4/0    RODISK    205.12 MB    RM    WP    RRD42
```

This line indicates an RRD42 compact disc drive, located at address ID 4 on the SCSI bus. The RRD42 compact disc is a read-only, removable disc and is write-protected (WP).

Note

The number of megabytes displayed for the RRD42 compact disc will vary, depending on the number of files loaded on the disc by the manufacturer.

Testing All Components Simultaneously

The system exerciser, which resides on the Read-Only Memory (ROM), is another tool you can use to verify whether you properly installed a new option or to isolate the problem if your system has intermittent problems.

The system exerciser tests all internal and external devices and components, except for memory and sound chips, simultaneously. The test takes from 5 to 15 minutes to complete, depending on the number of SCSI devices. It does not write on any medium.

To test your system, run the system exerciser as follows:

1. To test a drive, insert media in the SCSI devices on your system that support removable media. For example:
 - If your system has an RRD42 compact disc drive, insert a disc.
 - If your system has a TZK10 tape drive, insert a TZK10 tape cartridge.
 - If your system has an RX26 diskette drive, insert a formatted diskette.

Testing All Components Simultaneously

If the diskette is not formatted, the test will fail. To format the diskette, enter the following command:

```
>>> INIT/DENSITY=xx
```

Where xx represents:

ED Extra density

DD Double density

HD High density

The diskette in the drive must match the density that you specify with the INIT command. If you have a diskette that is different from what you specify in the command, the command fails and displays the following message:

```
Invalid media format
```



2. Put the system in console mode by pressing the halt button behind the front door of the system unit.

Note

Before halting or turning off your system, see the operating system documentation for shutdown procedures. If your system is part of a networked work group, do not turn off, halt, or restart the system without notifying work group members.

3. Enter the following command:

```
>>> TEST 100 
```

Testing All Components Simultaneously

Figure 6–4 shows a successful system exerciser test. As testing progresses, each status bar fills.

Figure 6–4 Successful System Exerciser Test

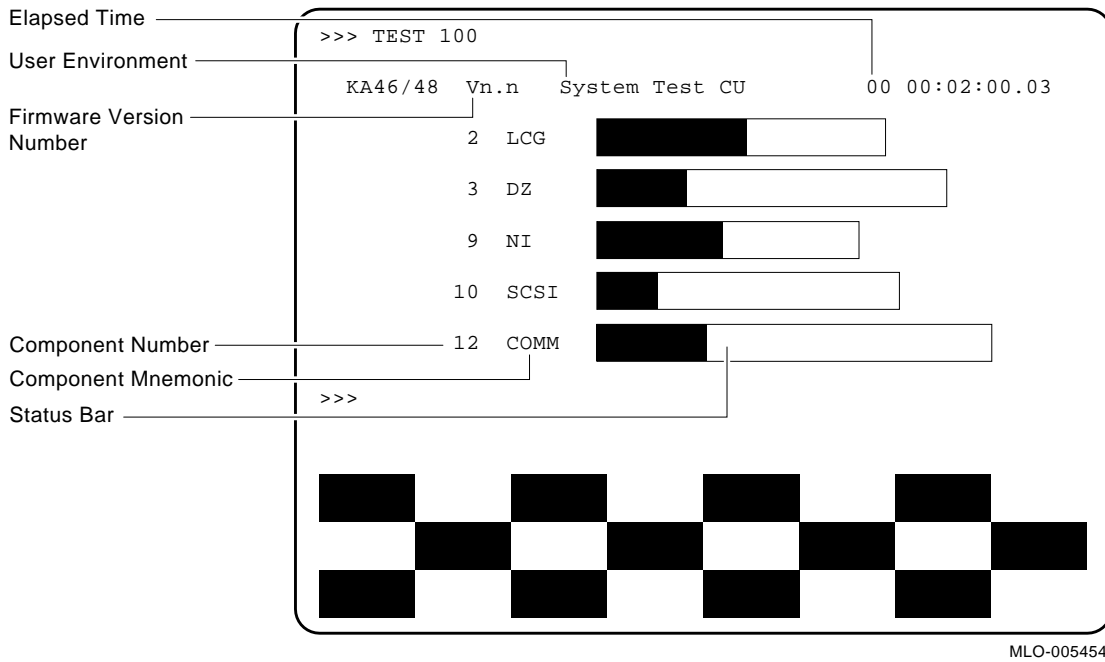

When the test finishes, the system exerciser displays the following question, asking if you want to see a summary display of the system test.

```
*****SYT_DISPPLY_SUMRY (('1'=Y), ('0'=N)).....?_
```

Testing All Components Simultaneously

If you answer 1 (yes) and there is an error, a display similar to the following is shown below the device names and their status bars:

```
*****FST ext_errpt 2lcg 0:00:02:03*****
LCG error summary - Pass count = 00000005
-----
error code      06A 010 0003
checker board   address          expect          read
                (drive number)  (code of what test  (code of what test
                                expected to read)  actually read)
-----
vram error
main mem error      (these two lines show where the error is)
-----
```

The display always begins with the LCG device. To see the display of each subsequent device, press the Return key.

If you answer 0 (no), a display similar to the following is shown:

```
?06 HLT INST
    PC=00000F09 PSL=00000000
>>>
```

This display tells you that the test is halting and the system is returning you to the console prompt (>>>):

After you request the summary display, the question is repeated. To return to the console prompt, answer 0 (no).

Testing All Components Simultaneously

Figure 6–5 shows a system exerciser display with an error line for component number 10, the SCSI controller.

Figure 6–5 System Exerciser Display with an Error Line

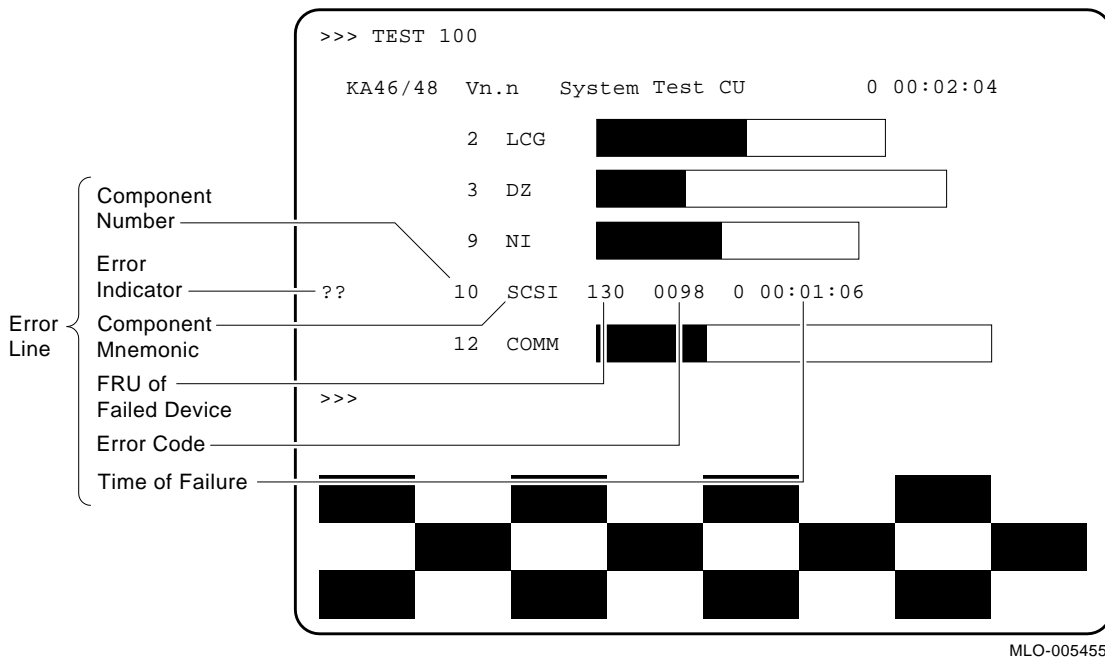

If you see any error messages, write down the firmware version number and the error number and call your Digital service representative for assistance. Table 6–1 identifies the device or component number that corresponds to each device or component mnemonic. Have this information ready when you call your Digital service representative.

Rebooting the System After Testing

While you are running any of the tests or procedures in this chapter, you are in console mode. To resume normal operation of the system, you must reenter program mode. There are two ways to enter program mode:

1. Enter `BOOT` at the console prompt (`>>>`) and press the Return key. The system searches each device in turn for the operating system software.

If you set the boot device using the `SET BOOT` command as shown in *Setting the Default Boot Device*, the system goes directly to the device set as the default boot device.

2. Enter `BOOT` followed by a space and one of the VMS device names listed in Table 6–4 for the device that contains your software.

Table 6–4 VMS Device Names

Device and Location	VMS Device Name
Fixed disk in system unit or expansion box (SCSI bus at ID 0–7)	DKAx00 ¹
Mass storage on remote system	ESA0
Tape (SCSI bus at ID 0–7)	MKAx00 ¹

¹x stands for the SCSI ID for a particular device. See Appendix B.

For example, to boot the system software immediately from the fixed disk at SCSI ID 3, enter:

```
>>> BOOT DKA300 
```

Depending on which boot device is used, after a short time, you will see a DECwindows window or the VMS username prompt.

See Appendix A for more information on setting your system parameters.

A

Alternate Startup Procedures

Use this appendix if you want to change the factory-set startup procedures. This appendix describes:

- Changing the Keyboard Language
- Setting the Default Boot Device
- Changing the Default Recovery Action
- Setting the Default Boot Flags
- Using an Alternate Console with Your System

Changing the Keyboard Language



To operate your system in a different language, you need to change the language of your keyboard as follows:

1. Put the system in console mode by pressing the halt button behind the door on the front of the system unit.

Note

Before halting or turning off your system, see the operating system documentation for shutdown procedures. If your system is part of a networked work group, do not turn off, halt, or restart the system without notifying work group members.

2. At the console prompt (`>>>`), enter `SET KBD` and press Return. The Keyboard Language Menu and the selected default are displayed, as shown in Figure A-1.

Changing the Keyboard Language

Figure A-1 Changing the Keyboard Language

```
>>> SET KBD

0) Dansk                      8) Francais (Suisse Romande)
1) Deutsch                    9) Italiano
2) Deutsch (Schweiz)         10) Nederlands
3) English                    11) Norsk
4) English (British/Irish)   12) Portugues
5) Espanol                   13) Suomi
6) Francais                   14) Svenska
7) Francais (Canadien)       15) Vlaams

3 >>>
```

MLO-005478

3. Select a language from the menu. For example, to change from English (3) to Italian (9), enter 9 at the console prompt and press Return.

Setting the Default Boot Device

When your system arrives from the factory, it is set to boot from a particular disk drive, which is the default boot device.

You can change the default boot device to any of the devices listed in Table A-1, but the operating system software must reside on that device. Table A-1 shows the VMS device names assigned to each of the possible devices.

Setting the Default Boot Device

Table A-1 SCSI Boot Device Names

Device	VMS Device Name
Fixed disk in system unit or expansion box (SCSI bus at ID 0-7)	DKAx00 ¹
Mass storage on remote system	ESA0
Tape (SCSI bus at ID 0-7)	MKAx00 ¹

¹x stands for the SCSI ID for a particular device.



To reset the default boot device, follow these steps.

1. Put the system in console mode by pressing the halt button behind the door on the front of the system unit.

Note

Before halting or turning off your system, see the operating system documentation for shutdown procedures. If your system is part of a networked work group, do not turn off, halt, or restart the system without notifying work group members.

2. At the console prompt (>>>), enter SET BOOT and the VMS device name of the boot device where the software will reside, then press Return. For example,

```
>>> SET BOOT DKA300 Return
```

This command sets the boot device to be the fixed disk at SCSI ID 3 in the system unit.

You can also speed up the boot process if you are powering your system off and on frequently. The following command shortens the time for the self-test, although the amount of time depends partly on the amount of memory you have on the system:

```
>>> SET FBOOT 1 Return
```

Changing the Default Recovery Action

The default recovery action is the system's automatic response when you turn the system on or after the system recovers from an operating system software failure. The options you have for setting this default recovery action are listed and explained in Table A-2.

Table A-2 Values for Recovery Action

Value	Recovery Action	Result	Action
1	Automatic restart	After system failure, the operating system restarts. If that fails, the system reboots.	None
2	Automatic reboot	The system halts and then the operating system software reboots.	None
3	Automatic halt	The system halts after powering-up, and the console prompt is displayed.	Enter BOOT ¹

¹Enter BOOT or BOOT plus the VMS device name for the device where the operating system software resides.

If you want to change the default recovery action, follow these steps:



1. Put the system in console mode by pressing the halt button behind the front door of the system unit.

Note

Before halting or turning off your system, see the operating system documentation for shutdown procedures. If your system is part of a networked work group, do not turn off, halt, or restart the system without notifying work group members.

2. At the console prompt (>>>), enter the following:

```
SHOW HALT 
```

Changing the Default Recovery Action

The value for the current default recovery action is displayed as follows:

```
>>> HALT 00000001
```

3. Enter a new default recovery value from those listed in Table A–2. In the following example, the new default recovery value is 2, which automatically reboots the operating system software after a system failure:

```
>>> SET HALT 2 
```

Setting the Default Boot Flags

The SET BFLG (boot flag) command lets you define parameters that the system will use each time it boots.

Note

This command should be used by only developers and other technical users who need and understand its capabilities. Most users will not need to change the boot flag setting.

Default boot flags should be preset for the operating system installed on your system. Consult your CPU technical manual for the default boot flag number (a hexadecimal number of up to 8 characters).



To reset the default boot flags:

1. Put the system in console mode by pressing the halt button behind the front door of the system unit.

Setting the Default Boot Flags

Note

Before halting or turning off your system, see the operating system documentation for shutdown procedures. If your system is part of a networked work group, do not turn off, halt, or restart the system without notifying work group members.

2. At the console prompt, enter:

```
>>> SET BFLG new_default-bootflag-number Return
```

Using an Alternate Console with Your System

If your monitor screen is blank, you can use the alternate console feature to run tests. By connecting a terminal to the printer/communications port, you can run tests on the graphics board or use the system exerciser to determine the cause of the monitor problem.

To connect a terminal, follow these steps:



1. Halt the system by pressing the halt button behind the front door of the system unit.

Note

Before halting or turning off your system, see the operating system documentation for shutdown procedures. If your system is part of a networked work group, do not turn off, halt, or restart the system without notifying work group members.



2. Turn off (O) the system unit.

Using an Alternate Console with Your System

S3

3. Move the alternate console switch behind the door on the front of the system unit to the up (on) position using a small pointed object. Do not use a pencil; the graphite will damage the switch. When the switch is in the up position, the terminal functions as an alternate console. The printer /communications serial port is now a terminal port.

With the alternate console switch in the up position, the system always attempts to use the serial line. The state of the alternate console switch is read only at power-up.

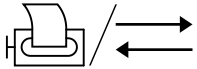

4. Attach one end of an RS423 serial cable to the printer/communications port on the back of the system unit and the other end of the serial cable to the serial port on the alternate console terminal.
5. Turn on (|) the terminal.
6. Check the baud rate of the terminal, which should be set to 9600 baud. See your terminal documentation for additional information on adjusting the baud rate.



7. Turn on (|) the system unit.
8. Adjust the brightness and contrast on your terminal.
9. If the console prompt (>>>) does not appear on the alternate console screen, press the Break key on the alternate console terminal keyboard.

B

SCSI ID Settings

The information in this appendix is for technically-trained users who wish to do custom configurations. The Small Computer Systems Interface, or SCSI, is an interface designed for connecting disk drives and other peripheral devices to computer systems. SCSI is defined by an American National Standards Institute (ANSI) standard and is used by computer and peripheral vendors throughout the industry.

You can add up to seven SCSI devices to the system on a SCSI bus. All data is sent between the system and the devices connected to the bus. Each of the seven SCSI devices is identified by a number from 0 to 7, called a SCSI ID. Each device looks at all the data on the bus, but receives only the data that has its SCSI ID.

This appendix explains:

- Recommended SCSI ID Settings
- Resetting SCSI IDs

Recommended SCSI ID Settings

Digital sets each SCSI device to a SCSI ID before the equipment leaves the factory. These settings should be changed *only* when you configure a system with more than one of the same device. You are responsible for the SCSI ID settings on your equipment.

Recommended SCSI settings for each system are listed in Table B-1. For most applications, SCSI IDs can be set arbitrarily as long as no two devices share the same ID.

Table B-1 Recommended SCSI IDs for the System Unit

ID	Device
0	RZ23L, RZ24, RZ25 fixed disk drives
1	RZ23L, RZ24, RZ25 fixed disk drives
2	RZ23L, RZ24, RZ25 fixed disk drives
3	Reserved for an RZ23L, RZ24, or RZ25 fixed disk drive installed at the factory
4	RRD42 compact disc drive
5	Tape drive (TZK10) or diskette drive (RX26)
6	Reserved for the SCSI controller
7	Any high-priority device

Resetting SCSI IDs

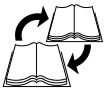

Each SCSI device has a set of switches or jumpers (removable electrical connectors) that can be set to a specific ID. Figures B-1 and B-2 show SCSI device switches and jumpers, respectively.

Figure B-1 SCSI Device Switches

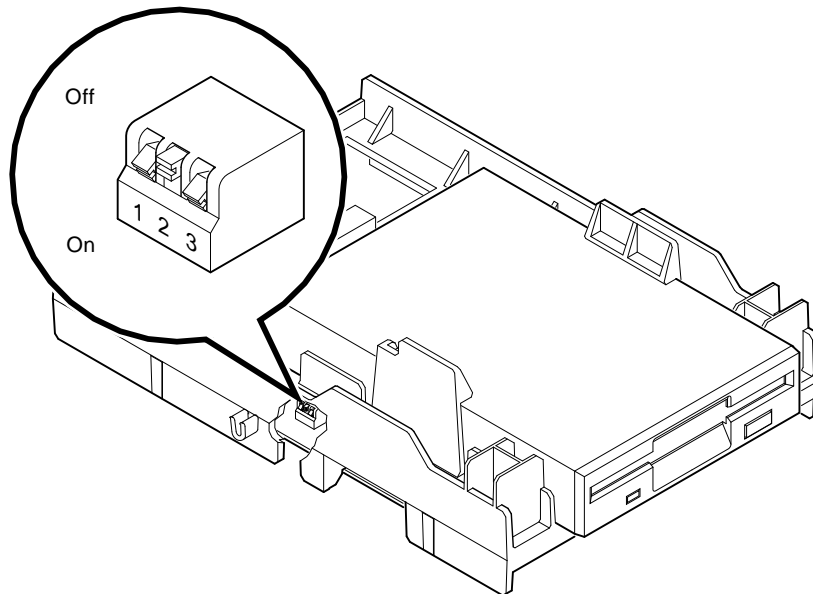

MLO-005898

Figure B-2 SCSI Device Jumpers

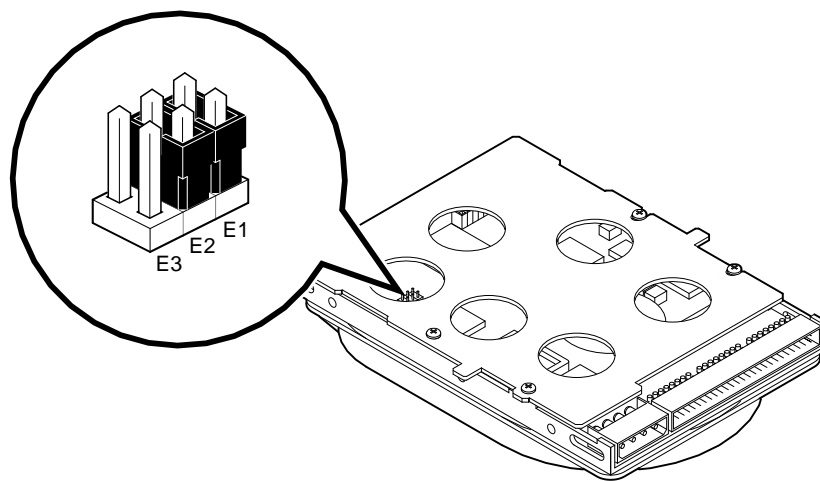

MLO-005907

In addition, the SZ03 SCSI Expansion Box has a small numeric dial that you simply turn to the correct ID number. Since the way to set SCSI ID numbers varies with the device, do not try to change a SCSI ID number without first knowing which method to use.

To reset the SCSI ID on an installed internal device, you need to open the system unit. You can use any available ID number on the SCSI bus when you set ID switches for a particular device. See the *VAXstation 4000 Options Installation Guide* for instructions on how to open the system unit and to locate and reset the SCSI switch or jumper positions for each SCSI ID available for a particular internal device. To set SCSI switches for devices in a storage expansion box, see the *BA46 Storage Expansion Box Owner's Guide* that comes with your BA46 storage expansion box or the *SZ03 Storage Expansion Box Owner's Card* that comes with your SZ03 Storage Expansion Box.

Resetting SCSI IDs

Follow these rules when you reset SCSI IDs:

- You can connect up to seven devices on one SCSI bus.
- Each device must have a unique SCSI ID.
- The length of the Digital SCSI bus cannot be more than 4 meters (13 ft).

Note

Proper operation of the SCSI bus requires that you use high-quality cables and connectors to connect all devices. Digital recommends that you use Digital-supplied cables intended for interconnecting SCSI devices. Digital also recommends that you power all units on the SCSI bus from a common AC power source. The proper operation of any SCSI bus that uses cable not supplied by Digital, or not configured in accordance with Digital's recommendations, is not guaranteed.

To display status information about each SCSI ID on your system, enter `SHOW CONFIG` at the console prompt (`>>>`), then press Return. Your system configuration appears on the screen in a display similar to the one in Figure B-3.

Resetting SCSI IDs

Figure B-3 Status Information on SCSI IDs

```
>>> SHOW CONFIG
KA46-A Vn.n
08-00-2B-0A-7D-CB
8MB
DEVNBR  DEVNAM  INFO
-----  -
 1      NVR      OK
 2      LCG      OK
          LR-MONO FB-1.0
 3      DZ       OK
 4      CACHE    OK
 5      MEM      OK
          8MB = SY=8MB, S0/1=0MB, S2/3=0MB, S4/5=0MB
 6      FPU      OK
 7      IT       OK
 8      SYS      OK
 9      NI       OK
10     SCSI     OK
SCSI Line ----- 0-RZ23L  5-RZ24  6-INITR
SCSI ID Number ----- 11 AUD OK
Component Mnemonic ----- 12 COMM OK
>>>
```

MLO-005457

Functioning SCSI devices are displayed on the SCSI line of the system configuration display. In Figure B-3, the SCSI ID number for the RZ24 fixed disk drive is 5. If a device that is installed on the system is not listed on the SCSI line, there could be a malfunction in the device.

C

Console Commands and the Password Security Feature

The commands that you enter at the console prompt (>>>) let you display information about your system, as well as set and test certain components. This appendix is intended as a reference for experienced users and describes:

- Console Commands
- The Password Security Feature

Console Commands

To see a list of console commands, enter `HELP` at the console prompt (>>>) and press Return.

Tables C-1, C-2, and C-3 list the `SHOW`, `SET`, and `TEST` commands along with the information displayed or the tests or utility programs they execute.

Console Commands

Table C-1 SHOW Commands

Command	Information Displayed
HELP	All commands
SHOW BFLG	Default boot flag (see Setting the Default Boot Device)
SHOW BOOT	Default boot device (see Setting the Default Boot Device)
SHOW CONFIG	Configuration display (see Using the SHOW CONFIG Command)
SHOW DEVICE	Boot devices available (see Using the SHOW DEVICE Command)
SHOW ERROR	Extended error information
SHOW ESTAT	Status of system exerciser tests
SHOW ETHER	Hardware Ethernet address
SHOW FBOOT	Default startup tests to perform
SHOW HALT	Default action after your system halts (see Changing the Default Recovery Action)
SHOW KBD	Keyboard language selected (see Changing the Keyboard Language)
SHOW MEM	Memory for your system unit
SHOW MOP	Turns the NI listener on and off; the default is 1 (off). Used for remote diagnostic purposes
SHOW PSE	Password enable bit (this must be set to use security feature)
SHOW SCSI	SCSI bus host ID number
SHOW VER	Version of ROM

Table C–2 SET Commands

Command	Meaning
SET BFLG	Allows you to set boot flags
SET BOOT	Allows you to define the boot device
SET HALT	Allows you to change the recovery action
SET KBD	Allows you to select the keyboard language
SET PSE	Allows you to enable the password bit
SET PSWD	Allows you to enable the password security feature
SET SCSI	Allows you to set the SCSI bus host ID number

Table C–3 TEST Commands

Command	Test or Utility Program
TEST AUD	Self-test on sound chip
TEST CACHE	Self-test on cache
TEST DZ	Self-test on serial line controller
TEST FPU	Self-test on floating point unit
TEST IT	Self-test on interval timer
TEST LCG	Self-test on low-cost graphics coprocessor option
TEST MEM	Self-test on system memory
TEST NI	Self-test on network interface
TEST NVR	Self-test on nonvolatile RAM
TEST SCSI	Self-test on device controller
TEST SYS	Self-test on interrupt controller and Ethernet ID ROM
T/UT SCSI	Utility that displays a list of disk formatter choices
TEST 13–99	Reserved for future use
TEST 100	System exerciser

The Password Security Feature

In normal operation, console mode (>>>) allows all console operator privileges, such as HALT, SET, DEPOSIT, and EXAMINE. However, some customers require that direct access to memory and kernel system operation be restricted to authorized personnel only. To implement this restricted access, a password security feature is available for console access and operation.

You invoke the password security feature by entering the console command LOGIN. (This is not the same as the VMS LOGIN command). The system asks for a 16-character password, after which it allows access to privileged console commands only to users possessing the correct password.

Examples of how to set the password are described in Setting the Password.

The privileged console commands are:

- BOOT (with parameters)
- DEPOSIT
- EXAMINE
- FIND
- HALT
- INITIALIZE
- LOAD
- MICROSTEP
- NEXT
- REPEAT
- SET
- SHOW
- START
- UNJAM
- X
- @

Any commands that modify memory and registers, or that transfer control of the CPU from the console monitor to another program such as BOOT or START.

The Password Security Feature

Access to the privileged console commands continues until the user leaves console mode by entering the `BOOT`, `CONTINUE`, `HALT`, or `START` commands. Subsequent entries into the privileged mode can be gained only by using the password.

Access to the console commands listed in Table C-4 is allowed in nonprivileged mode.

Table C-4 Nonprivileged Console Commands

<code>LOGIN</code>	Allows password entry to the privileged state.
<code>BOOT</code> (no parameters)	Allows you to boot from the default boot device.
<code>CONTINUE</code>	Allows continued operations in a nonprivileged mode if you inadvertently push the <code>HALT</code> button.
<code>!</code>	Allows comment text that will not be acted on by the system.

Setting the Password

Your system arrives from the factory with the password security feature disabled.

To set the password security feature on your system:

1. At the console prompt (`>>>`) enter `SET PSWD`.
The console responds with the prompt `PSWD0 >>>`.
2. Enter your password, which is not displayed or echoed on the screen.

Note

A password must be a character string of exactly 16 hexadecimal characters (0 through 9, A through F). It is important that you make a note of your password and store it in a secure place. If you forget your password, you must call your Digital service representative to regain access to the privileged console mode.

The console responds with the prompt `PSWD2 >>>`.

The Password Security Feature

3. Enter your password a second time for verification. Again, as you enter the password, it does not echo on the screen.

If the two passwords you entered match, your password is preserved in nonvolatile memory, which means that the password value is saved even if power is turned off at the system unit.

If the two passwords you entered do not match, then the console aborts the command and the following error message is displayed:

```
?34 ILL PSWD
```

Set your password again.

Enabling the Password

After you enter and confirm the password, you must enable the password security feature as follows:

1. To see the password feature status, enter `SHOW PSE` at the console prompt.

The console responds with:

```
PSE = 00000000
```

This indicates that the password security feature is not enabled.

2. To enable the password security feature, enter `SET PSE 1`.

The password security feature is now enabled. You can no longer use the privileged commands without logging in with the password at the console prompt.

3. To start using the password feature, enter `LOGIN`.

The console responds with the prompt `PSWD0 >>>`.

4. Enter your 16-character password.

If the password is accepted, you can use privileged commands as soon as you return to the console mode.

If the password is not accepted, the console responds with the following code:

```
?34 ILL PSWD
```

Enter your password again.

The Password Security Feature

Disabling the Password

To disable the password feature:

1. Be sure you are in privileged mode.
2. Enter SET PSE 0 at the console prompt.
The console responds with PSE = 00000000.

Changing the Password

To change the password:

1. Be sure you are in the privileged mode.
2. At the console prompt, enter SET PSWD.
The console responds with the prompt PSWD0 >>>.
3. Enter your old password, which is not displayed on the screen.
If you have correctly entered the old password, the console responds with the prompt PSWD1 >>>.
4. Enter your new password.
Again, as you enter the password, it is not displayed on the screen. The console responds with the console prompt PSWD2 >>>.
5. Enter your new password again, for verification.
If the two passwords you entered match, your new password is preserved in nonvolatile memory, so that the password value is saved, even if power is removed from the system unit.
If the two passwords you entered do not match, then the console aborts the command and the following error message is displayed:

```
?34 ILL PSWD
```

Try changing your password again.

If you forget your password, call your Digital service representative.

D

Hardware Specifications

This appendix gives the following specifications:

- System Unit Dimensions (Diskless System)
- System Specifications
- System Electrical Specifications
- System Environmental Specifications
- RZ23L Fixed Disk Drive Specifications
- RZ24 Fixed Disk Drive Specifications
- RZ25 Fixed Disk Drive Specifications
- RX26 Diskette Drive Specifications
- RRD42 Compact Disc Drive Specifications
- TZK10 Cartridge Tape Drive Specifications
- DSW21 Synchronous Communications Adapter Specifications

Hardware Specifications

Table D–1 System Unit Dimensions (Diskless System)

Weight	Height	Width	Depth
4½ kg (10 lb)	10.9 cm (4.3 in)	48.2 cm (19.0 in)	40 cm (15½ in)

Table D–2 System Specifications

Topic	Description
Processor	KA46–18 ns CPU and 2 KB primary and 256 KB secondary cache for the VAXstation 4000 Model 60
DRAM memory	8 MB on board
Optional DRAM	104 MB, maximum
ROM memory	256 KB
Optional fixed disks	One or two 121-MB, 209-MB, or 426-MB integral 3½-inch fixed disks
Optional RX26 diskette drive	4-MB 3½-inch, half-height diskette drive
Optional RRD42 compact disc	600-MB 5¼-inch, half-height compact disc drive
Optional TZK10	525-MB, 5¼-inch, half-height, quarter-inch cartridge (QIC) tape drive
Optional expansion boxes	BA46 storage expansion box or SZ03 Storage Expansion Box
Interfaces	1 SCSI port, 1 ThinWire Ethernet port, 1 standard Ethernet port, and serial ports such as printer/communications and communications /printer

Table D–3 System Electrical Specifications

Topic	Description
Input voltage	Automatically adjusting AC input from 100–120 VAC to 220–240 VAC
Frequency range	47 to 63 Hz
Watts	286 maximum, with no monitor 465 maximum, with monitor

Table D–4 System Environmental Specifications

Storage Conditions	
Temperature range	5°C to 50°C (41°F to 122°F)
Relative humidity	10% to 95% (noncondensing)
Altitude	0 to 2400 m (0 to 8000 ft)
Maximum wet bulb temperature	32°C (90°F)
Minimum dew point	2°C (36°F)
Operating Conditions	
Temperature range	15°C to 32°C (59°F to 90°F)
Temperature change rate	11°C/hr (52°F/hr) maximum
Relative humidity	20%–80% (noncondensing)
Altitude	2400 m (8000 ft)
Maximum wet bulb temperature	28°C (82°F)
Minimum dew point	2°C (36°F)
Nonoperating Conditions	
Temperature range	–40°C to 66°C (–40°F to 151°F)
Relative humidity	95% @ 66°C (151°F) (may condense)
Altitude	4900 m (16,000 ft)
Maximum wet bulb temperature	28°C (82°F)
Minimum dew point	2°C (36°F)

Hardware Specifications

Table D-5 RZ23L Fixed Disk Drive Specifications

Formatted Storage Capacity	
Per drive	121 MB
Per surface	30 MB
Bytes per track	19,968
Bytes per block	512
Blocks per track	39
Spare blocks per track	1
Blocks per drive	237,588
Spare blocks per drive	6092
Spare cylinders	0
Buffer size	64 KB

Performance	
Data transfer rate to/from media	1.5 MB/sec
Data transfer rate to/from buffer	1.13 MB/sec
Bus asynchronous	3.0 MB
Bus synchronous	4.0 MB
Seek time track to track	≤ 8 msec
Seek time average	≤ ≤ 19 msec
Seek time maximum (full stroke)	≤ 35 msec
Average latency	8.8 msec
Rotational speed	3409 rpm ±0.5%
Start time	20 sec maximum
Stop time	20 sec maximum
Interleave	1:1

(continued on next page)

Table D–5 (Cont.) RZ23L Fixed Disk Drive Specifications

Operating Conditions	
Ambient temperature	10°C to 55°C (50°F to 131°F)
Relative humidity	8%–80%
Altitude	–304 m to 3048 m (–1000 ft to 15,000 ft)
Maximum wet bulb	25.6°C (78°F) (noncondensing)
Heat dissipation	3.6 W (typical) (12.31 Btu/hr) 3.8 W max. (seeking)(13.0 Btu/hr)
Temperature gradient	11°C/hr (52°F/hr)
Nonoperating Conditions	
Ambient temperature	–40°C to 66°C (–40°F to 151°F)
Relative humidity	8%–95% (packaged)
Altitude	–304 m to 12,192 m (–1000 ft to 40,000 ft)
Maximum wet bulb	46°C (115°F) (noncondensing)
Temperature gradient	20°C/hr (68°F/hr)

Table D–6 RZ24 Fixed Disk Drive Specifications

Formatted Storage Capacity	
Per drive	209.7 MB
Per surface	26.2 MB
Bytes per track	19,456
Bytes per block	512
Blocks per track	38
Blocks per drive	409,792
Spare blocks per track	1
Spare blocks per drive	10,944
Spare cylinders	0

(continued on next page)

Hardware Specifications

Table D–6 (Cont.) RZ24 Fixed Disk Drive Specifications

Formatted Storage Capacity	
Buffer size	64 KB
Performance	
Data transfer rate to/from media	1½ MB/sec
Data transfer rate to/from buffer	1.13 MB/sec
Bus asynchronous	3.0 MB
Bus synchronous	4.0 MB
Seek time track to track	5 msec
Seek time average	16 msec
Seek time maximum (full stroke)	≤ 35 msec
Average latency	8.6 msec
Rotational speed	3497 rpm ±0.5%
Start time	20 sec maximum
Stop time	20 sec maximum
Interleave	1:1
Operating Conditions	
Ambient temperature	10°C to 55°C (50°F to 131°F)
Relative humidity	8%–80%
Altitude	–304 m to 4573 m (–1000 ft to 15,000 ft)
Maximum wet bulb	25.6°C (78°F) (noncondensing)
Heat dissipation	6.8 W (seeking) (23.26 Btu/hr) 6.6 W (typical) (22.57 Btu/hr)
Temperature gradient	11°C/hr (20°F/hr)

(continued on next page)

Table D–6 (Cont.) RZ24 Fixed Disk Drive Specifications

Nonoperating Conditions	
Ambient temperature	–40°C to 66°C (–40°F to 151°F)
Relative humidity	8%–95% (packaged)
Altitude	–304 m to 12,192 m (–1000 ft to 40,000 ft)
Maximum wet bulb	46°C (115°F) (noncondensing)
Temperature gradient	20°C/hr (68°F/hr)

Table D–7 RZ25 Fixed Disk Drive Specifications

Formatted Storage Capacity	
Per drive	426 MB
Per surface	47.3 MB
Bytes per track	24,576–37,376 (variable)
Bytes per block	512
Blocks per track	48
Blocks per drive	832,031
Spare blocks per track	1
Spare blocks per drive	14,148
Spare cylinders	2
Buffer size	60 KB

(continued on next page)

Hardware Specifications

Table D-7 (Cont.) RZ25 Fixed Disk Drive Specifications

Performance

Data transfer rate to/from media	2.1–3.2 MB/sec (variable)
Data transfer rate to/from buffer	2.33 MB/sec
Bus asynchronous	3.0 MB
Bus synchronous	4.0 MB
Seek time track to track	2½ msec
Seek time average	14 msec
Seek time maximum (full stroke)	28 msec
Average latency	6.8 msec
Rotational speed	4412 rpm ± 0.5%
Start time	20 sec maximum
Stop time	30 sec maximum
Interleave	1:1

Operating Conditions

Ambient temperature	10°C to 55°C (50°F to 122°F)
Relative humidity	8%–80%
Altitude	30.48 m to 304.78 m (–1000 ft to 10,000 ft)
Maximum wet bulb	25.6°C (78°F) (noncondensing)
Heat dissipation	12W (seeking) 10W (typical)
Temperature gradient	11°C/hr (20°F/hr)

(continued on next page)

Table D–7 (Cont.) RZ25 Fixed Disk Drive Specifications

Nonoperating Conditions	
Ambient temperature	–40°C to 66°C (–40°F to 151°F)
Relative humidity	8%–95% (packaged)
Altitude	–1000 ft to 10,000 ft
Maximum wet bulb	46°C (115°F)
Temperature gradient	20°C (68°F/hr)

Table D–8 RX26 Diskette Drive Specifications

Topic	Description
Diskette size	3½ inches
Diskettes per diskette drive	1
Storage capacity	4 MB unformatted, 2.9 MB formatted (ED)
	2 MB unformatted, 1.4 MB formatted (HD)
	1 MB unformatted, 720 KB formatted (DD)

Hardware Specifications

Table D–9 RRD42 Compact Disc Drive Specifications

Topic	Description
Capacity per disc	600 MB
Access time	Full stroke 650 msec (typical) Average (1/4 stroke) 380 msec (typical)
Data transfer rate	Sustained rate 150 KB/sec Burst rate 1½ MB/sec
Environmental Specifications	Operating Conditions
Temperature range	5°C to 50°C (41°F to 122°F)
Relative humidity	10% to 90%, noncondensing
Altitude	20 m (8000 ft) at 36°C (96°F)
Maximum wet bulb temperature	29°C (84°F)
Minimum dew point temperature	2°C (36°F)
Environmental Specifications	Nonoperating
Temperature range	–30°C to 55°C (–22°F to 131°F)
Relative humidity	10% to 90%, noncondensing
Altitude	13,600 m (44,600 ft) at 36°C (96°F)
Maximum wet bulb temperature	46°C (115°F)
Minimum dew point temperature	2°C (36°F)

Table D–10 TZK10 Cartridge Tape Drive Specifications

Topic	Description
Mode of operation	Streaming
Drive interface	SCSI-2
Dimensions	44 mm (1.732 in)H x 146.05 mm (5.75 in)W x 208.28 mm (8.20 in)D
Weight (without cartridge)	1.1 kg (2.4 lb)
Media	DC6320/DC6525 tape cartridge or Digital approved equivalent (see Table 3–2)
Track width, write	0.1778 mm +0.0000/–0.0127 mm (0.0070 inches +.0000 inches/–0.0005 inches)
Track width, read	0.1270 mm +0.0127/–0.0000 mm (0.0050 inches +.0005 inches/–0.0000 inches)
Data density	16,000 bpi
Number of tracks	26
Data transfer rate	200 KB at average streaming mode 1½ MB at SCSI maximum
Tape speed	3.05 cm/s (120 ips)
Track format	Multiple track serpentine recording
Storage capacity	320 MB, formatted (approx. DC6320 cartridge) 525 MB, formatted (approx. DC6525 cartridge)
Power requirements	+12 V ± 5% @ 1.0 A (2.0 A surge), 150 mV ripple peak-to-peak +5 V ± 5% @ 1.2 A (1.8 A surge), 150 mV ripple peak-to-peak
Nominal power consumption	20 watts
Peak power consumption	33 watts

(continued on next page)

Hardware Specifications

Table D–10 (Cont.) TZK10 Cartridge Tape Drive Specifications

Environmental Specifications	Operating
Temperature range	5°C to 40°C (41°F to 104°F)
Relative humidity	20% to 80% maximum
Altitude	2.4 km (13,000 ft)
Environmental Specifications	Nonoperating
Temperature range	–30°C to +60°C (–22°F to 140°F)
Relative humidity	10% to 90% maximum
Altitude	4.9 km (40,000 ft)

Table D–11 DSW21 Synchronous Communications Adapter Specifications

Topic	Description
Operating Conditions	
Temperature range	5°C to 50°C (41°F to 122°F)
Temperature rate of change	20°C per hour (68°F per hour)
Relative humidity	10%–95% (noncondensing)
Maximum wet bulb	32°C (90°F)
Minimum dew point	2°C (36°F)
Atmospheric pressure	Maximum altitude 8000 feet
Power supply variation	±5%
Nonoperating Conditions	
Relative humidity	10%–95%
Atmospheric pressure	Maximum altitude 16000 feet
Storage Conditions	
Temperature range	–40°C to 66°C (–40°F to 151°F)
Relative humidity	10%–95%
Maximum wet bulb temperature	46°C (115°F)

E

Associated Documents

For option and system hardware part numbers, consult your Digital sales representative.

Not all the following documents are available in every country. Check with your Digital sales representative for availability.

Table E-1 lists the VAXstation 4000 online documents available on compact disc (Bookreader). Table E-2 lists the associated documents available in printed form.

Table E-1 VAXstation 4000 Bookreader Documents

Titles

VAXstation 4000 Model 60 Owner's and System Installation Guide

VAXstation 4000 Options Installation Guide

BA46 Storage Expansion Box Owner's Guide

Associated Documents

Table E-2 Associated Printed Documents

Titles	Order Numbers
VAXstation 4000 Family	
<i>VAXstation 4000 Model 60 Owner's and System Installation Guide</i>	EK-PMARI-OM
<i>VAXstation 4000 Options Installation Guide</i>	EK-PMARI-IG
<i>BA46 Storage Expansion Box Owner's Guide</i>	EK-STEXP-OM
<i>SZ03 Storage Expansion Box Owner's Card</i>	EK-SDDBY-OG
<i>Vertical Floor Stand Installation Guide</i>	EK-FLRST-IN
<i>VAXstation 4000 VLC Setting Up Your Workstation Card</i>	EK-INTRE-QC
<i>VAXstation 4000 VLC Adding Memory Card</i>	EK-INTNA-QC
<i>VAXstation 4000 VLC Adding an Internal Disk Drive Card</i>	EK-PERDE-QC
Service Documentation	
<i>VAXstation 4000 Documentation Kit</i>	EK-V4666-DK
<i>VAXstation 4000 Model 60 Service Information</i>	EK-V466H-SV
<i>VAXstation 4000 VLC Service Information</i>	EK-V48VB-SV
<i>VAXstation 4000 Model 60 Optional Devices Service Information</i>	EK-V4066-SV
<i>VAXstation 4000 Model 60 Service Information</i>	EK-V466B-SV
<i>VAXstation 4000 VLC and Model 60 Pocket Service Information</i>	EK-V466H-PS
<i>BA46 Expansion Service Information</i>	EK-VBA46-SV

(continued on next page)

Table E-2 (Cont.) Associated Printed Documents

Titles	Order Numbers
Workstation Family	
<i>Workstation Family Technical Summary</i>	EC-H0742-51
Drives	
<i>RRD42 Compact Disc Drive Owner's Manual</i>	EK-RRD42-OM
<i>RX26 Owner's Reference Card</i>	EK-RX26D-RC
<i>TZK10 Cartridge Tape Drive Owner's Guide</i>	EK-TZK10-OG
<i>RZ Series Disk Drive Subsystem</i>	EK-RZXXD-PS-003
DECconnect System	
<i>DECconnect System General Description</i>	EK-DECSY-GD
<i>DECconnect System Requirements Evaluation Workbook</i>	EK-DECSY-EG
<i>DECconnect System Installation and Verification Guide</i>	EK-DECSY-VG
<i>DECconnect System Stand-alone ThinWire Networks: Planning and Installation Guide</i>	EK-DECSY-TG
<i>DECconnect System Planning and Configuration Guide</i>	EK-DECSY-CG
SCSI	
<i>Small Computer System Interface: An Overview</i>	EK-SCSIS-OV
<i>Small Computer System Interface: A Developer's Guide</i>	EK-SCSIS-SP

(continued on next page)

Associated Documents

Table E-2 (Cont.) Associated Printed Documents

Titles	Order Numbers
VMS Software Documentation Kits	
Base Set	QA-09SAA-GZ
<i>VMS User's Manual</i>	
<i>VMS System Manager's Manual</i>	
<i>VMS License Management Utility Manual</i>	
VMS DECwindows User Kit (2 manuals)	
General User Subkit	QA-001A1-GZ
General Information (3 manuals)	
Using VMS (6 manuals)	
Using DCL (2 manuals)	
DCL Dictionary (2 manuals)	
Processing Text (4 manuals)	
System Messages (2 manuals)	
System Management Subkit	QA-001A2-GZ
Setup (10 manuals)	
Maintenance (6 manuals)	
Security (4 manuals)	
Performance (4 manuals)	
Networking (4 manuals)	
Programming Subkit	QA-001A3-GZ
Introduction (3 manuals)	
Programming Utilities (7 manuals)	
System Routines (2 manuals)	
System Services (2 manuals)	
Run-Time Library (8 manuals)	
File System (6 manuals)	
System Programming (4 manuals)	
Device Support (2 manuals)	
VAX MACRO	
VAX TPU (2 manuals)	

F

Port Pin-outs

This appendix is for users who want to connect communications devices to their system. The following tables explain the port pins on the back of the system unit:

- Printer/Communications Port Pin-Outs
- Asynchronous Communications Port Pin-Outs
- DSW21 Synchronous Communications Port Pin-Outs
- H3199 Multistandard Loopback Connector Pinning

Table F-1 Printer/Communications Port Pin-Outs

Pin Number	Meaning
1	Data Terminal Ready (DTR)
2	Transmit
3	Ground
4	Ground
5	Receive
6	Data Set Ready (DSR)

Port Pin-outs

Table F-2 Asynchronous Communications Port Pin-Outs

Pin Number	Meaning
1	Protective ground optional
2	Transmit data
3	Receive data
4	Request to send
5	Clear to send
6	Data set ready
7	Ground
8	Carrier detect
9	Not used
10	Not used
11	Not used
12	Speed detect
13	Not used
14	Not used
15	Not used
16	Not used
17	Not used
18	Receiver signal element timing
19	Not used
20	Data terminal ready
21	Not used
22	Calling indicator
23	Data signal rate selector
24	Not used
25	Test

Table F-3 DSW21 Synchronous Communications Port Pin-Outs

Pin Number	Signal Name	34-Pin BC19X Adapter V.35 Interface ¹	15-Pin BC20Q Adapter X.21 Interface	25-Pin BC19V Adapter V.24 Interface	25-Pin BC19Q Adapter EIA530 Interface	37-Pin BC19U Adapter RS422 Interface	37-Pin BC19W Adapter RS423 Interface
1	Code ground ²						
2	Code 0	Code ground	Code ground				
3	Code 1		Code ground	Code ground			Code ground
4	Code 2				Code ground	Code ground	
5	Code 3						
6	Transmit data A		2		2	4	
7	Transmit data B		9		14	22	
8	Transmit data			2			4
9	Request to send (RTS) RTS/C A		3		4	7	
10	RTS/C B		10		19	25	
11	Receive data A		4	3	3	6	6
12	Receive data B		11	DTE ground	16	24	24
13	Local loop			18	18	20	20

¹These six columns list the pin name or number of each adapter cable to which the corresponding 50-pin connector pin attaches

²Code ground is the common point for code inputs

(continued on next page)

Port Pin-outs

Table F-3 (Cont.) DSW21 Synchronous Communications Port Pin-Outs

Pin Number	Signal Name	34-Pin BC19X Adapter V.35 Interface ¹	15-Pin BC20Q Adapter X.21 Interface	25-Pin BC19V Adapter V.24 Interface	25-Pin BC19Q Adapter EIA530 Interface	37-Pin BC19U Adapter RS422 Interface	37-Pin BC19W Adapter RS423 Interface
14	Speed indicator						
15	Test indicator			25	25	18	18
16	Remote loop			21	21	14	14
17	Ring indicator	J		22	22	15	15
18	Receive clock A		6	17	17	8	8
19	Receive clock B		13	DTE ground	9	26	26
20	Transmit clock A		7	15	15	5	5
21	Transmit clock B		14	DTE ground	12	23	23
22	Clock			24			
23	V35 Transmit clock A	Y					
24	V35 Transmit clock B	a					
25	V35 Clock A	U					
26	V35 Clock B	W					

¹These six columns list the pin name or number of each adapter cable to which the corresponding 50-pin connector pin attaches

(continued on next page)

Table F-3 (Cont.) DSW21 Synchronous Communications Port Pin-Outs

Pin Number	Signal Name	34-Pin BC19X Adapter V.35 Interface ¹	15-Pin BC20Q Adapter X.21 Interface	25-Pin BC19V Adapter V.24 Interface	25-Pin BC19Q Adapter EIA530 Interface	37-Pin BC19U Adapter RS422 Interface	37-Pin BC19W Adapter RS423 Interface
27	V35 Receive data A	R					
28	V35 Receive data B	T					
29	V35 Transmit data A	P					
30	V35 Transmit data B	S					
31	V35 Receive clock A	V					
32	V35 Receive clock B	X					
33	Data terminal ready (DTR)	H		20			12
34	Data set ready (DSR) A	E		6	6	11	11
35	DSR B	DTE ground		DTE ground	DTE ground	29	29
36	RTS C	C		4			7
37	DCD/I A	F	5	8	8	13	13

¹These six columns list the pin name or number of each adapter cable to which the corresponding 50-pin connector pin attaches

(continued on next page)

Port Pin-outs

Table F-3 (Cont.) DSW21 Synchronous Communications Port Pin-Outs

Pin Number	Signal Name	34-Pin BC19X Adapter V.35 Interface ¹	15-Pin BC20Q Adapter X.21 Interface	25-Pin BC19V Adapter V.24 Interface	25-Pin BC19Q Adapter EIA530 Interface	37-Pin BC19U Adapter RS422 Interface	37-Pin BC19W Adapter RS423 Interface
38	DCD/I B	DTE ground	12	DTE ground	10	31	31
39	Clear to send (CTS) A	D		5	5	9	9
40	CTS B	DTE ground		DTE ground	13	27	27
41	DCE Ground	DTE ground		DTE ground	23	20	20
42	Test 1 (checksum)						
43	Test 2 (static RAM)						
44	DTE Ground	B	8	7	7	19,37	19,22,25,30,35,37
45	DTR A				20	12	
46	DTR B					30	
47	Clock A				24	17	
48	Clock B				11	35	
49	Test 3 (controller chip self test)						
50	Speed selector			23		16	16

¹These six columns list the pin name or number of each adapter cable to which the corresponding 50-pin connector pin attaches

Figure F-1 shows the location of the synchronous communications port pins.

Figure F-1 Synchronous Communications Port Pins

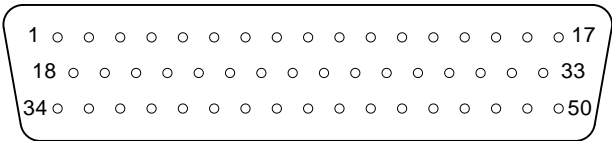

MLO-005141

The H3199 multistandard loopback connector is included with the DSW21 Synchronous Communications Adapter. Table F-4 shows how the H3199 is wired.

Table F-4 H3199 Multistandard Loopback Connector Pinning

Pin Number	Signal Description
1—5	Cable code (all grounded)
35, 41, 4	Grounds and receiver inputs
6 and 11	Data — channel A
7 and 12	Data — channel B
9 and 37	RTS/C and DCD/I — channel A
10 and 38	RTS/C and DCD/I — channel B
13 and 15	Local loop and test indicator
16 and 34	Remote loop and DSR — channel A
17 and 50	Speed select and ring indicator
47, 18, 20	Clock, Rx clock, Tx clock — channel A
48, 19, 21	Clock, Rx clock, Tx clock — channel B
45 and 39	DTR and CTS — channel A
46 and 40	DTR and CTS — channel B
33 and 14	DTR and Test 4

(continued on next page)

Port Pin-outs

Table F-4 (Cont.) H3199 Multistandard Loopback Connector Pinning

Pin Number	Signal Description
8 and 42	Data and Test 1
36 and 43	RTS and Test 2
29 and 27	V.35 data — channel A
30 and 28	V.35 data — channel B
25, 23, 31	V.35 clock — channel A
26, 24, 32	V.35 clock — channel B
22 and 49	Clock and Test 3

G

Error Messages

This appendix describes the most common error messages that you may see when turning on your system or running a self-test. If you see other messages that you do not understand, call your Digital service representative to order the *VAXstation 4000 Model 60 Service Information Kit*.

Messages are reported in a variety of formats; each format includes an error number that explains the problem. Table G-1 describes error messages according to their error number.

Error Messages

Table G-1 Error Messages

Error Message	Meaning	Action
030	There is no COMM loopback connector.	Be sure the COMM loopback connector is securely installed. If the error persists, enter the SHOW ERROR command to display a coded explanation. Call your Digital service representative to report the code.
040	The COMM option self test failed.	Be sure the DSW21 Synchronous Communications Adapter is securely connected and run the self test again.
0112	You are running tests and using the round mouse.	Disregard this message; the mouse is fine.
0166	Terminator is not secure.	Secure terminator and check all network cables.
0172	T-connector or Ethernet loopback connector is not secure or is not installed.	Secure or install the T-connector and check all network cables.

H

DSW21 Synchronous Communications Adapter Installation Information for the United Kingdom

This appendix includes the following installation information, which is required for the United Kingdom only:

- Cable Approval
- Equipment Between the DSW21 Synchronous Communications Adapter and a Digital Circuit
- Host Power Rating
- Approved Service Specifications
- BABT Host-Independent Approvals

Cable Approval

The DSW21 Synchronous Communications Adapter is approved for direct connection to a particular digital circuit. This approval includes an interconnecting cable with mating connectors that conform to the British standard BS6623, parts 1 and 4. If the adapter is connected to the service with anything other than its own approved cables, those cables must benefit from relevant general approval NS/G/1235/100009 and/or conform with any other application requirements.

Warning

The port indicated by the label "SAFETY WARNING: See Instructions for Use" does not provide sufficient isolation to satisfy the requirements of the relevant parts of standard BS6301. Any product connected to this port must meet one of the following conditions:

- Be covered by the general approval NS/G/1234/J /100003
- Have been approved to the relevant parts of standard BS6301
- Have previously been evaluated against British Telecom (Post Office) Technical Guide 2 or 26 and given permission to attach

Any other use of this product invalidates approval.

Direct or indirect interconnection of the port marked "SAFETY WARNING — See Instructions for Use" as indicated above, whether the ports are marked or not, may produce hazardous conditions on the network. You should obtain advice from a competent engineer before making such a connection.

Equipment Between the DSW21 Synchronous Communications Adapter and a Digital Circuit

If any other equipment, including cables or wiring, is to be connected between the DSW21 Synchronous Communications Adapter and any digital Postal Telephone and Telegraph (PTT) circuit, that equipment must conform as follows:

- The overall transmission characteristics of all other equipment must not have any material effect on the electrical conditions between the equipment and the digital circuit.

Equipment Between the DSW21 Synchronous Communications Adapter and a Digital Circuit

- All other equipment must comprise only the following:
 - Approval, which may be subject to limitations on its use, for the purpose of connection between it and a particular digital circuit.
 - Cable or wiring that complies with the standard installation code for the equipment or other requirements that may be applicable.

Host Power Rating

Since the host and the approved equipment are proprietary to Digital Equipment Corporation, Digital controls the power source and sink ratings. All available host enclosures have the power capacity to supply all module permutations.

Digital has designed all permutations of the host configuration to operate within the limits of the host power rating, as shown in Table H-1.

Table H-1 Module Power

Parameter	Minimum	Type	Maximum	Units
Power-consumption	–	6.7	8.01	Watts
Current at	+5V	.60	.75	Amperes
each DC	+12V	.12	.15	Amperes
voltage	-12V	.08	.10	Amperes

Approved Service Specifications

Table H-2 lists the British Approvals Board for Telecommunications (BABT) service specifications for UK compliance. Note the following relative to this table:

- The total length of cable must not exceed 27 feet.
- Use only cables that have been approved for the DSW21 Synchronous Communications Adapter. You can use other approved cables if they conform to the NS/G/1235/100009 standard and any other special requirements.

Table H-2 BAPT Approved Service Specifications for the DSW21 Synchronous Communications Adapter for UK Compliance

Service Category	Interface Type (CCITT recommended)	Service Requirements		Data Rate	Public Telecommunications Operators ¹		
		Physical	Electrical		BT	Hull	MCL
1	X.21bis	V.24 /V.28	ISO 2110, BS.6623: part1, 1985.	2400 bps	Yes	Yes	Yes
				4800 bps	Yes	Yes	Yes
				9600 bps	Yes	Yes	Yes
				19200 bps	No	No	Yes
Approved adapter cable: BC19V-02 Approved extension cable: BC19L-25 (25 feet)							
2	X.21bis	V.35	ISO 2593, BS.6623: part4, 1986.	48K bps	Yes	Yes	Yes
				56K bps	Yes	No	Yes
				64K bps	No	No	Yes
Approved adapter cable: BC19X-02 Approved extension cable: BC19L-25 (25 feet)							

¹BT — British Telecommunications plc.
Hull — Kingston Communications (Hull) plc.
MCL — Mercury Communications Limited.

BABT Host-Independent Approvals

When the DSW21 Synchronous Communications Adapter is approved by BABT, it can be installed only in an approved host with approved attachments. For approval, the host and attachments must be either of the following:

- Type-approved for the DSW21
In other words, the equipment is all built exactly as the models that were originally approved
- If the equipment was supplied after 1st March 1989, it must be marked with or supplied with a statement that the host is supplied under General Approval Number NS/G/1234/J/100003.

Except at the 64-pin connector that plugs into the host's expansion slot, clearance and creepage distances of Xmm and Ymm, as listed in Table H-3 must be maintained between the DSW21 Synchronous Communications Adapter and other parts of the host, including other expansion cards.

Table H-3 Clearance and Creepage Distances

Clearance Xmm	Creepage Ymm	Voltage Used or Generated by Other Parts of the Host or Expansion Card Vrms or Vdc
2.0	2.4 (3.8) ¹	Up to 50
2.6	3.0 (4.8)	Up to 125
4.0	5.0 (8.0)	Up to 250
4.0	6.4 (10.0)	Up to 300

¹The distances shown in parentheses apply in an uncontrolled environment where heat, humidity, and temperature may fluctuate.

The creepage distances apply when the DSW21 is installed in a controlled environment.

BABT Host-Independent Approvals

You can check creepage distances by measuring the distance between adjacent parts, as shown in Figure H-1, where:

- X Indicates the clearance distance, that is, the shortest distance in air between two points.
- Y Indicates the creepage path between the same two points, that is, the continuous path along the surface.

Figure H-1 Creepage Distance

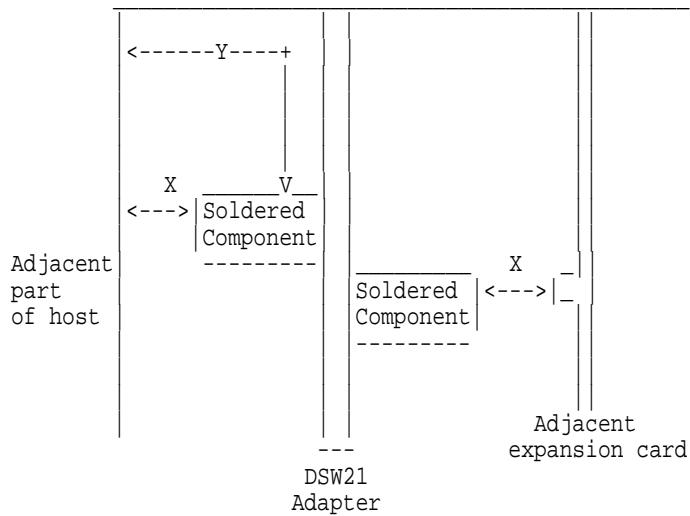

If in doubt, you should seek the advice of a telecoms safety engineer.

Failure to install the DSW21 Synchronous Communications Adapter in accordance with these instructions will invalidate the approval.

Glossary

alternate console feature

A feature that allows you to receive system messages on and direct system activities from an alternate terminal, if necessary, to diagnose problems with the monitor.

ANSI

American National Standards Institute.

applications

Programs, such as a financial spreadsheet program, that perform end-user tasks.

architecture

The internal configuration of a computer including its registers, instruction set, and input/output structure.

backup

A copy of files or software made for safekeeping. Also, the process of making copies of the data stored on your disk so that you can recover that data after an accidental loss. You make backup copies on tape cartridges, or over a network using the Remote System Manager.

baud rate

The speed at which signals are serially transmitted along a communications line. One baud equals 1 bit per second.

bezel

The removable molded panel on the front and back of the system unit. Certain bezels shipped with particular devices, such as the TZK10 or RRD42 drives, are designed to provide access to the front of the device after it is installed.

bit

A binary digit; the smallest unit of information in a binary system of notation, designated as a 0 or a 1.

boot

To bring a device or system to a defined state where it can operate on its own.

boot device

The device on which the operating system software is loaded.

boot flag

A setting that determines from where the system will boot. Default boot flags should already be set when you receive your system.

bus

A cable along which communication signals in a computer system travel.

byte

A group of 8 binary digits (bits). A byte is one-quarter of a VAX system word. See also **kilobyte** and **megabyte**.

cable

A sheathed group of electrical conductors.

caddy

The holder for an RRD42 compact disc.

CD

See **compact disc**.

client

A piece of hardware or software that obtains a specific set of services from a server.

cluster

A group of networked computers that share disk storage, application programs, and other computer resources. Also called a VAXcluster.

command

A request you make to the operating system to perform a specific function, for example, a request to run a program or show the configuration of a system.

communication

The flow of information from one point (the source) to another (the receiver).

compact disc

A flat circular plate on which read-only optical data is stored. A laser optical reader retrieves this information.

component

A basic part, or element, of your system that can be either internal or external. Compare to **device**.

configuration

See **system configuration**.

connector

Hardware that connects directly to a port on the system.

console

A device through which an operator communicates with the computer.

console commands

Commands input when the system is in console mode.

console mode

The state in which the computer is controlled directly by user commands from the console terminal rather than indirectly through the operating system. Put your system in console mode by pressing the halt button on the front of the system unit. Console mode is indicated by the console prompt (>>>) on the monitor screen. Compare to **program mode**.

console prompt

The prompt (>>>) that appears on the screen when the system is in console mode.

controller

A system component, usually a printed circuit board, that regulates the operation of one or more devices.

cursor

A blinking symbol on the screen that indicates where the next character you type will appear.

data

A formal representation of information suitable for communication, interpretation, and processing by computers.

database

A collection of interrelated data on one or more mass storage devices. The collection is organized to facilitate efficient and accurate inquiry and update.

DECconnect

Digital's simple, cost-effective cabling system for extending Ethernet and terminal interconnections into offices and work areas.

DECnet network

Digital networking software that runs on nodes in both **local** and **wide area networks**.

DECwindows

An interface to the VMS operating system that allows a workstation screen to be divided into windows where several application programs can appear simultaneously and commands can be executed using menus and a mouse. See also **window**.

default

A value or setting that is in effect unless another value or setting is specified.

default recovery action

The action that the system takes after a power or system failure.

device

The general name for any hardware unit connected to the system and capable of receiving, storing, or transmitting data. Examples of devices are drives and units that you can install into the system unit or an expansion box.

device name

The name by which a device or controller is identified in the system.

diagnostics

Programs, located in read-only memory, that detect and identify abnormal system hardware operation.

disc

See **compact disc**.

disk

A flat circular plate with a coating on which data is magnetically stored in concentric circles (tracks). A fixed disk resides permanently inside a disk drive, whereas a diskette is removable.

disk drive

A device that holds one or more disks. The drive contains mechanical components that spin the disks and move the read and write heads that store and read the information on the surface of the disks.

diskette

A flexible disk contained in a square jacket. Diskettes can be inserted and removed from diskette drives.

diskette drive

A disk drive that reads from or writes to a removable diskette. The VAXstation 4000 Model 60 uses the RX26 diskette drive.

diskless system

A system that has no storage capacity of its own.

DISMOUNT

A command to delete a device from the list of recognized devices on the system.

distributed application

An application in which part of the application functions are distributed to other systems over the network for processing. This distribution provides more efficient use of system resources.

drive leader

A plastic leader inside a tape drive. The cartridge leader on the magnetic tape and the drive leader on the tape drive come together. The drive leader draws the magnetic tape out of the tape cartridge and onto a take-up reel inside the drive. As the tape is wound onto the take-up reel, it passes the magnetic read and write heads.

error line

A line of information that appears if a self-test or a power-up test fails. The following information appears on the error line:

- Field replaceable unit (FRU) number
- Component number
- Component mnemonic
- Error message number

For example:

```
001 9 NI 172
```

error message number

A number that appears on the error line representing a particular system or component problem.

Ethernet

A type of local area network based on Carrier Sense Multiple Access with Collision Detection (CSMA/CD); a communications concept for local communication networks that use coaxial cable.

Ethernet hardware address

The unique Ethernet physical address associated with a particular Ethernet communications controller.

Ethernet subsystem

Refers to the Ethernet controller chip built into the system board.

expansion box

A box that holds additional system devices.

faceplate

A wall receptacle that provides a single network connection for your workstation.

fatal error

An error from which a process cannot recover. Fatal errors are either those that cause the CPU to stop, or disk write errors other than those caused by the disk drive being powered down or write-locked.

field replaceable unit (FRU)

A part of the system that can be replaced by your Digital service representative.

file

A collection of related information treated by the system as a unit.

firmware

Software that is stored in a fixed way (wired in), usually in read-only memory.

fixed disk

A disk that resides permanently inside a disk drive. Compare to **diskette**.

fixed disk drive

The disk drive that holds and reads from or writes to a fixed disk.

gigabyte (GB)

The measure used to refer to memory or secondary storage capacity, equal to 1,000 megabytes or 1,048,576,000 bytes.

ground

A large conducting body used as a common return for an electric circuit and as an arbitrary zero voltage of potential.

hardware

The physical equipment—mechanical and electrical—that makes up a system. Compare to **software**.

housing

The plastic case in which a compact disc sits. See also **caddy**.

icon

A symbol on the back or front of the system unit that identifies a port to which a cable or power cord can be connected.

input/output (I/O) device

A piece of equipment that transmits data to (input) and from (output) the system. For example, a terminal or a mouse. See **mouse**.

interface

An electronic circuit board that links an external device to a computer. Also, a device or piece of software that allows a user to communicate with the system or allows the components of the system to communicate with each other.

kilobyte (KB)

The measure use to refer to memory or secondary storage capacity, equal to 1,024 bytes.

local

In close proximity to the computer. Compare to **remote**.

local area network (LAN)

A high-speed communications network that covers a limited geographical area, such as a section of a building, an entire building, or a cluster of buildings. It is a privately owned communication network whose speed is upward of one megabit per second.

local console mode

A device that allows you to interact directly with the system without requiring the password security feature. Compare to **privileged console mode**.

local device

A disk drive, tape drive, or other device that is only available to the computer to which it is connected.

log in

The means of identifying yourself to the operating system. When you log in, you type an account name and password. If the name and password match an account on the system, you are allowed access to that account.

loopback connector

An Ethernet or communications connector used on the back of the system unit when testing the Ethernet subsystem or the synchronous COMM adapter.

magnetic tape

A tape, made of plastic and coated with magnetic oxide, that is used to store data. Also called magtape.

media

The physical material on which data is recorded, for example, magnetic disks, diskettes, and compact discs.

megabyte (MB)

A unit of measure equal to 1,000 kilobytes or 1,048,576 bytes.

memory

The area of the system that electrically stores instructions and data, often temporarily.

mnemonic

The abbreviation used by the system to identify a device or controller in the system.

modem

A device that converts computer signals to signals that can be sent over a telephone line.

module

A printed circuit board that contains electrical components and electrically conductive pathways between components. A module stores data or memory or controls the functions of a device.

monitor

A video device that displays data.

mouse

A hand-held input device that is moved across the desktop to move the pointer or cursor on the monitor screen and to select menu options and draw graphics. The mouse is palm-sized and contains three buttons (function keys).

network

Two or more computers linked by communication lines to share information and resources.

network coordinator

The person who manages the network, assigns unique node names and addresses for each system on the network, and provides administrative assistance to network users.

node

A computer, workstation, or peripheral device that is connected to a network and that can communicate with other members of the network.

node name

A name that identifies a unique node.

nonvolatile memory

Memory in which values are stored even when the system is turned off.

online documentation

Documents that can be read directly on your monitor screen. Online documentation is stored on a compact disc and includes all text and illustrations found in the printed manuals. Fast access time and cross-referencing are two advantages of online documentation.

operating system

An integrated collection of programs that controls the operation of the system and allows users access to data files, input/output devices, and application programs.

parity

A method of checking whether binary numbers or characters have been transmitted correctly by counting the 1 bits.

password

A unique string of characters or numbers, or both that identifies you to the computer.

password security feature

The feature that restricts access to certain console commands. To use all console commands, users must enter a password.

peripheral device

A device that provides the central processing unit (CPU) with additional memory storage or communication capability. Examples are disk and diskette drives, video terminals, and printers.

pointing device

A terminal input device that allows you to make a selection from a menu or to draw graphics. See **mouse** and **tablet**.

port

A socket on the front or back of the computer to which a terminal, printer, modem or other device is connected.

power-up

A series of ordered events that occur when you supply power by turning on the system.

privileged console commands

The commands allowed by the password security feature. See **password security feature**.

privileged console mode

The state the system is in when the password security feature is enabled. See **password security feature**.

process

A program currently using memory and running on the system.

program

The sequence of instructions the system uses to perform a task. See **software**.

program mode

The state in which the computer is controlled by the operating system. After the operating system is installed, the system always operates in program mode, unless you put it into console mode. Compare to **console mode**.

prompt

A symbol displayed by a program or an operating system, indicating that you are to provide input.

puck

A palm-sized device that slides on a tablet's surface. The puck and tablet together function as a pointing device. See **pointing device** and **tablet**.

random access memory (RAM)

Memory that can be both read from and written to and that can randomly access any one location during normal operations. The type of memory the system uses to store the instructions of programs currently being run.

read-only memory (ROM)

Memory that cannot be modified. The system can use (read) the data contained in ROM but cannot change it.

register

A storage location in hardware logic other than main memory.

remote

Physically distant from a computer, but linked to a computer by communication lines. Compare to **local**.

removable media device

A device such as the RRD42, TZK10, or RX26 drives from which the storage medium is removable.

ROM

See **read-only memory (ROM)**.

satellite

A node that is booted remotely from the system disk on the boot node. Also, a computer system that obtains a specific set of services from a server system.

SCSI

See **Small Computer System Interface**.

SCSI bus

A communications pathway between the Small Computer System Interface (SCSI) and up to seven disks and other peripheral devices.

section

A single length of ThinWire Ethernet cable terminated at each end with a connector.

segment

A length of ThinWire Ethernet cable made up of one or more cable sections connected with barrel connectors or T-connectors.

serial port

A port dedicated to hookups with serial line devices such as a terminal or printer. Serial devices transmit data one word after another (serially) along a single pair of lines from a sending device to a receiving device.

server

Hardware or software that provides a specific set of services to a satellite or client.

Small Computer System Interface (SCSI)

An interface designed for connecting disks and other peripheral devices to computer systems. SCSI, pronounced “skuh-zee,” is defined by an ANSI standard and is used by many computer and peripheral vendors throughout the industry.

software

Instructions executed by the system to perform a chosen or required function. Compare to **hardware**.

standalone network

A network that starts and operates alone, without being connected to another network.

standalone workstation

A workstation that starts and operates alone without being connected to another computer.

standard Ethernet network

An Ethernet network connected with standard Ethernet cable. (Also known as ThickWire Ethernet). Compare to **ThinWire Ethernet network**.

storage device

A device, such as a diskette or tape, capable of recording information.

strain relief strap

See **universal strain relief strap**.

stylus

A penlike device that draws on the surface of a tablet and functions as a pointing device.

synchronous communication

Communication through a synchronous serial interface, also referred to as the COMM board. This option allows you to connect your system in one of two ways:

- Through a modem to a Wide Area Network (WAN)
- Directly to another system through a null modem; that is, a connection box that replaces two modems and their connecting wires. This allows two devices that are designed to interact through modems to be locally connected.

system

A combination of hardware, software, and peripheral devices that together perform specific processing operations.

system configuration

The combination of hardware and software that makes up a usable computer system.

system disk

The disk that stores the operating system and that starts the system and allows it to run properly.

system unit

The part of the system that contains the drives, memory, power supply and the computer itself.

tablet

An absolute-positioning input device composed of a flat-surfaced digitizing tablet and a puck or stylus. The tablet is a drawing surface. The puck and stylus are pointing devices that move the cursor on the monitor screen, draw graphics, and make selections from the menu.

tape cartridge

Housing for magnetic tape. The cartridge contains a reel of tape and a take-up reel. A cartridge is similar to a cassette, but of slightly different design.

tape drive

A device that contains mechanical components and holds, turns, reads, and writes on magnetic tape.

T-connector

A connector used to join ThinWire Ethernet cable sections.

terminal

A device for entering information into a computer system and displaying it on a screen. A typewriter-like keyboard, mouse, tablet or other pointing devices are used to enter information.

terminator

A connector used on one or both ends of an Ethernet segment that provides the 50-ohm termination resistance needed for the cable. A terminator is also used on both sides of a T-connector and on the SCSI port.

ThinWire Ethernet network

A Digital trademark used to describe its 10base2 (IEEE standard 802.3 compliant) Ethernet products used for local distribution of data.

timesharing

A system in which two or more programs are allotted, in turn, equal time or use of a computer or computer device.

universal strain relief strap

A plastic strap used when connecting the monitor video cable to the back of the monitor. The strap prevents the weight of the cable junction box from pulling the cables out of the BNC connectors.

user interface

The style of interaction between the computer and the user of that computer.

VAXcluster configuration

A group of two or more computers connected by an Ethernet cable. In a VAXcluster, one computer (the server) serves the other computers. The server is required to start the other computers, and it manages the resources that they share.

VMS device name

The name that the VMS operating system uses for a storage device to access that particular device.

VMS operating system

Digital Equipment Corporation's proprietary operating system.

volatile memory

Memory from which values are lost when the system is turned off.

wide-area network

A public or private data communications system in which transmissions are carried primarily over telephone lines.

window

An area on your monitor screen in which you can start, run, and view a separate process. Windowing capability is supported by both VMS and ULTRIX workstation software.

work group

Several workstations, connected together on a network, that perform similar tasks and share information or databases.

workstation

A single-user system that offers high-performance, high-resolution graphics, and can function in a network environment.

write-protect switch

The switch that you set on a tape cartridge or an RX26 diskette to prevent loss of data by accidental overwriting.

Index

??
error indicator, 4–8

A

Adding drives, 3–4
Air vents, 2–2
Alternate console
 setting the baud rate, A–8
 using, A–7
Alternate console switch
 location, 1–5
Alternate startup procedures
 setting, A–1 to A–7
ANSI standard
 SCSI, B–1
Associated documentation, E–1
Asynchronous communications port, pin outs,
 F–1
Automatic test display
 error line, 2–19
 failure, 2–19
 power up, 2–18

B

BOOT command, 6–16, A–5
 after running tests, 6–16
 automatic, A–3
Boot devices
 changing, A–4
 names of, A–3
 setting, A–3

Boot flags
 setting default, A–6

C

Cables
 troubleshooting, 5–2
Caddy
 loading a disc into, 3–8
 opening, 3–8
 shutter location, 3–8
Care and handling
 compact discs, 3–7
 diskettes, 3–13
 TZK10 tape cartridges, 3–18
Cartridge tape drive
 See TZK10 cartridge tape drive
Cartridges
 QIC, 3–18
 TZK10, 3–18
Commands
 BOOT, 6–16, A–3
 console, C–1
 diagnostic, C–3
 HELP, C–1
 privileged, C–4
 SET, C–2, C–3
 SET BFLG, A–6
 SET FBOOT, A–4
 SET KBD, A–2
 SHOW, C–1
 SHOW CONFIG, 6–7, 6–8
 SHOW DEVICE, 6–7, 6–9, 6–10
 TEST, 6–5, 6–8, 6–12, C–3

- Compact disc drives, 3–6
- Compact discs, 3–6
 - care of, 3–7
 - controls and indicators, 3–6
 - inserting, 3–11
 - loading, 3–8
 - removing, 3–12
 - removing protective film, 3–8
- Components
 - identifying faulty, 6–2
- Configuration display, 4–5
- Connecting to
 - ThinWire Ethernet Networks, 4–9 to 4–17
- Console commands, C–1
- Console mode, 6–16
 - getting help, C–1
 - security feature, C–4
- Conventions
 - used in this guide, xiv

D

- Default boot devices
 - changing, A–4
 - names of, A–3
 - setting, A–3
- Default boot flags
 - setting, A–6
- Default recovery action
 - setting, A–5
- Device display, 6–7
 - mnemonics, 6–9
- Device testing, 6–4
- Diagnostic commands, C–3
- Diagnostic lights, 5–11
 - location, 1–5
 - ThinWire error, 5–11
- Diagnostics
 - confirming options, 6–7
 - device, 6–4
 - Ethernet, 4–2
 - installed devices, 6–9
 - power-up, 6–2
 - self tests, 6–13

- Diagnostics (cont'd)
 - self-tests, 6–4
 - storage expansion box, 6–4
 - successful powerup display, 2–18
 - system configuration, 6–7
 - system exerciser, 6–11
- Digital service representative, 5–10
- Disc drive
 - See RRD42 compact disc drive
- Disk drives
 - See RZ23L fixed disk drive; RZ24 fixed disk drive; RZ25 disk drive
- Diskette drive, 3–17
- Diskettes
 - care of, 3–13
 - inserting, 3–16
 - installing software with, 3–15
 - removing, 3–17
 - write-protecting, 3–15
 - writing to, 3–15
- DKAx00 device, 6–16, A–3
- Drives
 - adding, 3–4
 - location, 3–4
 - RRD42 compact disc, 3–6
 - RX26 diskette, 3–13
 - TZK10 tape, 3–18
- DSW21 Synchronous Communications Adapter
 - description, 3–24

E

- Eject button, 3–17
- Environmental requirements, 2–2
- Error indicator (?), 4–8
- Error line, 2–19
- Error messages, 6–15, G–1
 - in system exerciser, 6–15
 - power-up display, 6–2
 - software, 5–7
- Errors
 - reporting, 2–19

ESA0 device, 6–16, A–3
Ethernet hardware address, 4–3
Ethernet network
 removing from ThinWire, 4–16
 standard, 4–9, 4–15
 testing, 4–2
 ThinWire, 4–9, 4–17
 troubleshooting, 4–15
Expansion boxes
 as default boot device, A–3

F

Fan
 troubleshooting, 5–3
Features, 1–3
Field Replaceable Unit (FRU) numbers, 6–6
Fixed disk drives, 3–5
 See RZ23L fixed disk drive; See RZ24
 fixed disk drive; See RZ25 disk drive
Fixed disks, 3–5
 as default boot device, A–3
 boot device names, 6–16, A–3
Front door
 location, 1–5

G

Grounding powerstrip, 2–2

H

Halt button, 6–4
 location, 1–5
Halt recovery action, A–5
Handling problems
 See also Troubleshooting
Hardware address, 4–3
Hardware specifications
 electrical, D–2
 environmental, D–2
 RRD42 compact disc drive, D–10
 RX26 diskette drive, D–9
 RZ23L fixed disk drive, D–4
 RZ24 fixed disk drive, D–5

Hardware specifications (cont'd)
 RZ25 fixed disk drive, D–7
 system unit, D–1
 TZK10 cartridge tape drive, D–11
HELP command, C–1

I

Icons
 used in this guide, xv
Installing software
 with diskettes, 3–15
Installing the system, 2–1

K

Keyboard
 changing language, A–2
 connecting to the system unit, 2–6
 language menu, A–2, A–3

L

Languages
 changing, A–2
Lights
 diagnostic, 5–11
 reading, 5–11
 troubleshooting, 5–11
Local Area VAXcluster (LAVc)
 setting up, 4–9
 ThinWire Ethernet hardware address for,
 4–4
Locating the workstation, 2–2
Loopback connector
 attaching to system unit, 2–9
 Ethernet, 2–9, 4–2, 4–8, 4–11

M

Magnets
 keeping media away from, 3–13
Margin icons
 used in this guide, xv

MKAx00 device, 6-16, A-3
Mnemonics
 devices, 6-7
 power-up, 6-3
 SHOW DEVICE command, 6-10

Monitor
 attaching the cable, 2-13
 attaching the power cord, 2-14
 brightness and contrast controls, 3-2
 positioning, 2-2
 troubleshooting, 5-3

Monitor cable
 attaching the Universal Strain Relief
 Strap, 2-11
 attaching to the monitor, 2-13
 attaching to the system unit, 2-10

Mouse
 connecting to the system unit, 2-6
 using, xvi

N

Network coordinator, 4-9
Network diagnostics
 and power-up display, 6-2
Network switch
 setting for standard Ethernet, 4-9
 setting for ThinWire Ethernet, 4-9
Networks, 4-1 to 4-17
 See also Local area network; Local area
 VAXclusters; Standard Ethernet
 networks; ThinWire Ethernet
 network; Work group
Node address, 4-9
Node name, 4-3, 4-9

O

On/off switch
 location, 1-5
Operating system software
 boot device names, 6-16, A-3
 booting, A-3

Options
 confirming installation, 6-1, 6-7
 devices available, 1-7
Outlets, grounded, 2-2

P

Password
 setting, C-5
Password security feature
 changing, C-7
 disabling, C-7
 enabling, C-6
 setting, C-4
Port pin-outs
 asynchronous communications, F-1
 printer/communications, F-1
Power cord
 connecting to the system unit, 2-10, 2-15
Power strip, 2-2
Power up
 automatic test display, 2-18
 error messages, 6-2
 failure, 2-19
 mnemonics, 6-3
 successful test display, 6-5
 system exerciser, 6-13
 tests, 6-2
 troubleshooting, 5-3
Printer/communications port
 pin outs, F-1
Privileged console commands, C-4
Problem solving, 5-1, 5-2
 system exerciser, 6-11
 troubleshooting table, 5-3
Problems
 identifying, 6-4
 reporting, 5-10, 6-6
Program mode, 6-16

Q

Quarter-inch cartridge (QIC), 3–18

R

Reboot recovery action, A–5
Rebooting, A–5
Recording system information, 2–22
Remote booting, A–3
 boot device name, 6–16, A–3
Reporting problems, 2–19, 5–10
Restart recovery action, A–5
Restarting your system, 6–16
RRD42 compact disc
 loading into a caddy, 3–8
RRD42 compact disc drive
 boot device name, 6–16, A–3
 error message, 6–13
 hardware specifications, D–10
 loading software with, 3–6
 SCSI ID, B–2
RX26 diskette drive, 3–13 to 3–17
 eject button, 3–17
 hardware specifications, D–9
 inserting a diskette, 3–16
 removing a diskette, 3–17
 storage capacity, 3–13
RZ23L fixed disk drive
 boot device name, 6–16, A–3
 hardware specifications, D–4
 SCSI ID, B–2
 storage capacity, 3–5
RZ24 fixed disk drive
 boot device name, 6–16, A–3
 hardware specifications, D–5
 SCSI ID, B–2, B–6
 storage capacity, 3–5
RZ25 fixed disk drive, 3–5
 hardware specifications, D–7
 SCSI ID, B–2
 storage capacity, 3–5

S

SCSI devices
 boot names, A–3
 troubleshooting, 5–6
SCSI IDs
 default setup, A–3
 definition of, B–1
 recommended settings, B–2
 resetting, B–3
 RRD42 compact disc drive, B–2
 RZ23L fixed disk drive, B–2
 RZ24 fixed disk drive, B–2, B–6
 RZ25 fixed disk drive, B–2
 TZK10 cartridge tape drive, B–2
Segment
 ThinWire cable, 4–13
Self-tests, 6–4
 restarting after, 6–16
 system exerciser, 6–13
Service, 5–10
SET BFLG command, A–6
SET commands, C–2, C–3
SET FBOOT command, A–4
SET HALT command, A–5
SET KBD command, A–2
Setting up the system, 2–1
 identifying system parts, 2–5
 placing the system unit, 2–6
SHOW commands, C–1
SHOW CONFIG command, 6–7, 6–8
 display, 4–5, 4–6
 using to confirm options, 6–7
SHOW DEVICE command, 6–7, 6–9
 mnemonics, 6–10
Shutdown procedures, 3–2
Site preparation, 2–2
Software installation
 using diskette drive for, 3–15
Specifications, D–1
 electrical, D–2
 environmental, D–2
 RRD42 compact disc drive, D–10
 RX26 diskette drive, D–9

Specifications (cont'd)

- RZ23L fixed disk drive, D-4
- RZ24 fixed disk drive, D-5
- RZ25 fixed disk drive, D-7
- system, D-2
- TZK10 cartridge tape drive, D-11

Standard Ethernet network

- setting network switch for, 4-9
- troubleshooting, 4-15

Status bar

- at power-up, 6-2
- definition of, 6-2

Storage devices

- See RRD42 compact disc expansion box;
RZ23L fixed disk drive; RZ24 fixed
disk drive

Storage expansion box

- testing, 6-4

Surge protector, 2-2

Synchronous communications adapter

- See DSW21 Synchronous Communications
Adapter

System

- features, 1-3
- overview, 1-3
- unpacking, 2-5

System exerciser

- display example, 6-13
- restarting after running, 6-16
- successful test, 6-13
- test with errors, 6-14
- testing media, 6-11
- when to use, 6-11

System information

- recording, 2-22

System unit

- attaching the Ethernet loopback
connector, 2-9
- attaching the monitor cable, 2-10
- attaching the power cord, 2-10, 2-15
- attaching the T-connector, 2-9
- connecting a keyboard, 2-6
- connecting a mouse, 2-6
- diagnostic lights, 5-11
- dimensions, D-2

System unit (cont'd)

- electrical specifications, D-2
- environmental specifications, D-2
- hardware specifications, D-1
- positioning, 2-2
- troubleshooting, 5-3
- turning off, 3-2
- turning on, 2-17, 3-2

T

T-connector

- troubleshooting, 4-15

Tape drives

- boot device name, 6-16, A-3

Temperature requirements, 2-2

TEST 100 command, 6-12

TEST command, 6-4, 6-5, 6-8, 6-12, C-3

Testing

- Ethernet network, 4-2
- system, 2-18, 2-19

ThinWire Ethernet network

- cable segment, 4-13
- connecting to, 4-9 to 4-17
- creating a work group, 4-13
- removing a system, 4-16
- setting network switch for, 4-9
- troubleshooting, 4-15

ThinWire T-connector

- assembling, 2-8
- attaching terminators, 2-8
- attaching to system unit, 2-8, 2-9
- improper connection error, 5-11

Troubleshooting

- lights (LEDs), 5-11
- monitor, 5-3
- power-up error messages, 6-2
- SCSI devices, 5-6
- self-tests, 6-4
- standard Ethernet, 4-15
- system exerciser, 6-11
- system unit, 5-3
- table, 5-3
- ThinWire Ethernet, 4-15

Turning off the system
 sequence for components, 3-2, 5-2, 5-3

Turning on the system
 sequence for components, 3-2

TZK10 cartridge tape drive
 cartridges, 3-18
 controls and indicator lights, 3-21
 description, 3-18
 eject button, 3-23
 guidelines, 3-18
 inserting a cartridge, 3-22
 removing a cartridge, 3-23
 SCSI ID, B-2
 specifications, D-11
 storage capacity, 3-18
 using, 3-18
 write-protecting cartridges, 3-19

TZK10 tape cartridges
 care of, 3-18

U

Universal Strain Relief Strap
 attaching to the monitor cable, 2-11

Unpacking the system, 2-5

V

Ventilation, 2-2

VMS operating system
 See also Operating system
 boot device names, 6-16, A-3
 device name
 booting and, 6-16

W

Wide area network device drive (WANDD),
 3-24

Windowing software, xvi

Work group
 creating, 4-13

Workstation
 turning off, 3-2
 turning on, 3-2

Write-protect switch
 for diskette, 3-15

Write-protecting diskettes, 3-15

Writing to diskettes, 3-15

How to Order Additional Documentation

Technical Support

If you need help deciding which documentation best meets your needs, call 800-DIGITAL (800-344-4825) and press 2 for technical assistance.

Electronic Orders

If you wish to place an order through your account at the Electronic Store, dial 800-234-1998, using a modem set to 2400- or 9600-baud. You must be using a VT terminal or terminal emulator set at 8 bits, no parity. If you need assistance using the Electronic Store, call 800-DIGITAL (800-344-4825) and ask for an Electronic Store specialist.

Telephone and Direct Mail Orders

From	Call	Write
U.S.A.	DECdirect Phone: 800-DIGITAL (800-344-4825) Fax: (603) 884-5597	Digital Equipment Corporation P.O. Box CS2008 Nashua, NH 03061
Puerto Rico	Phone: (809) 781-0505 Fax: (809) 749-8377	Digital Equipment Caribbean, Inc. 3 Digital Plaza, 1st Street Suite 200 Metro Office Park San Juan, Puerto Rico 00920
Canada	Phone: 800-267-6215 Fax: (613) 592-1946	Digital Equipment of Canada Ltd. 100 Herzberg Road Kanata, Ontario, Canada K2K 2A6 Attn: DECdirect Sales
International	—————	Local Digital subsidiary or approved distributor
Internal Orders ¹ (for software documentation)	DTN: 264-3030 (603) 884-3030 Fax: (603) 884-3960	U.S. Software Supply Business Digital Equipment Corporation 10 Cotton Road Nashua, NH 03063-1260
Internal Orders (for hardware documentation)	DTN: 264-3030 (603) 884-3030 Fax: (603) 884-3960	U.S. Software Supply Business Digital Equipment Corporation 10 Cotton Road Nashua, NH 03063-1260

¹Call to request an Internal Software Order Form (EN-01740-07).

Reader's Comments

VAXstation 4000 Model 60
Owner's and System Installation
Guide
EK-PMARI-OM. A02

Your comments and suggestions help us improve the quality of our publications.

Thank you for your assistance.

I rate this manual's:	Excellent	Good	Fair	Poor
Accuracy (product works as manual says)	<input type="checkbox"/>	<input type="checkbox"/>	<input type="checkbox"/>	<input type="checkbox"/>
Completeness (enough information)	<input type="checkbox"/>	<input type="checkbox"/>	<input type="checkbox"/>	<input type="checkbox"/>
Clarity (easy to understand)	<input type="checkbox"/>	<input type="checkbox"/>	<input type="checkbox"/>	<input type="checkbox"/>
Organization (structure of subject matter)	<input type="checkbox"/>	<input type="checkbox"/>	<input type="checkbox"/>	<input type="checkbox"/>
Figures (useful)	<input type="checkbox"/>	<input type="checkbox"/>	<input type="checkbox"/>	<input type="checkbox"/>
Examples (useful)	<input type="checkbox"/>	<input type="checkbox"/>	<input type="checkbox"/>	<input type="checkbox"/>
Index (ability to find topic)	<input type="checkbox"/>	<input type="checkbox"/>	<input type="checkbox"/>	<input type="checkbox"/>
Page layout (easy to find information)	<input type="checkbox"/>	<input type="checkbox"/>	<input type="checkbox"/>	<input type="checkbox"/>

I would like to see more/less _____

What I like best about this manual is _____

What I like least about this manual is _____

I found the following errors in this manual:

Page	Description
_____	_____
_____	_____
_____	_____

Additional comments or suggestions to improve this manual:

For software manuals, please indicate which version of the software you are using: _____

Name/Title _____ Dept. _____

Company _____ Date _____

Mailing Address _____

Phone _____

Do Not Tear - Fold Here and Tape

digital™

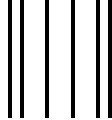

No Postage
Necessary
If Mailed
in the
United States

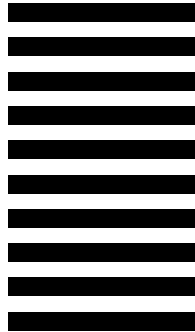

BUSINESS REPLY MAIL
FIRST CLASS PERMIT NO. 33 MAYNARD MASS.

POSTAGE WILL BE PAID BY ADDRESSEE

DIGITAL EQUIPMENT CORPORATION
Information Design and Consulting
PKO3-1/D30
129 PARKER STREET
MAYNARD, MA 01754-2198



Do Not Tear - Fold Here