

Outline: History

Lecturer: Hans-Jürgen Wollersheim

e-mail: h.j.wollersheim@gsi.de

web-page: <https://web-docs.gsi.de/~wolle/> and click on

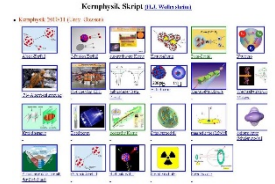

1. Rutherford scattering
2. natural particle acceleration
3. electrostatic accelerator
4. Cockroft Walton multiplier
5. Van de Graaf accelerator

History

- ❖ 1862: Maxwell theory of electromagnetism
- ❖ 1886: Goldstein discovers positively charged rays (ion beams)
- ❖ 1887: Hertz discovery of electromagnetic wave
- ❖ 1894: Lenard extracts cathode rays (with a 2.65 μm Al Lenard window)
- ❖ 1897: J.J. Thomson shows that cathode rays are particles since they followed the classical Lorentz force $m\vec{a} = e \cdot (\vec{E} + \vec{v} \times \vec{B})$ in electromagnetic field
- ❖ 1926: G.P. Thomson showed that the electron is a wave



Philipp E.A. von Lenard
(1862-1947)

Nobel prize 1905

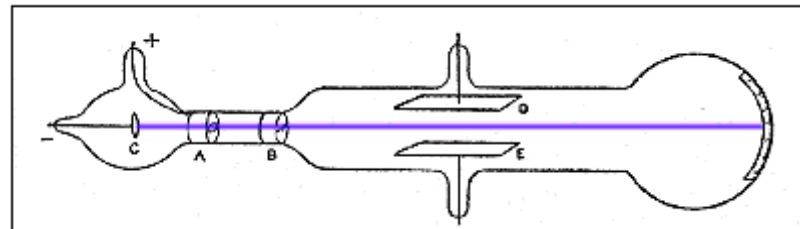

Joseph J. Thomson
(1856-1940)

Nobel prize 1906

Rutherford scattering

- ❖ 1909: Ernest Rutherford discovers the nucleus with 7.7 MeV ${}^4\text{He}$ from ${}^{214}\text{Po}$ alpha decay measuring the elastic cross section

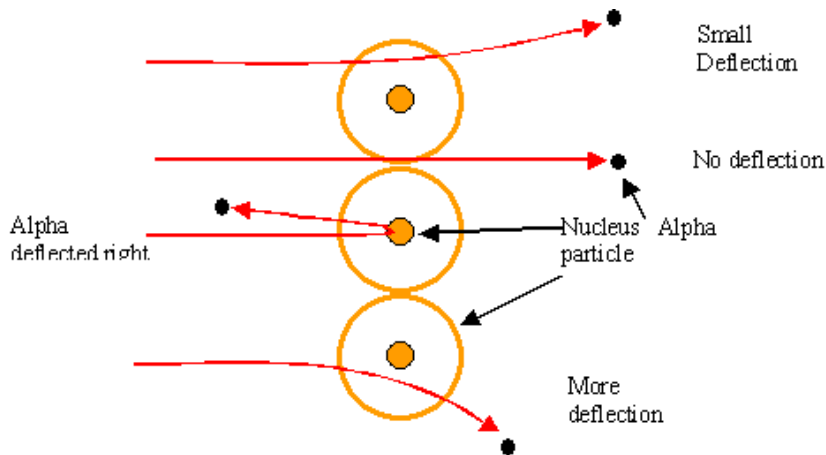

$$E_{\alpha} = \frac{1}{4\pi\epsilon_0} \frac{Z_{\alpha} \cdot Z_{Au} \cdot e^2}{d}$$

d = distance of closest approach for head-on collision

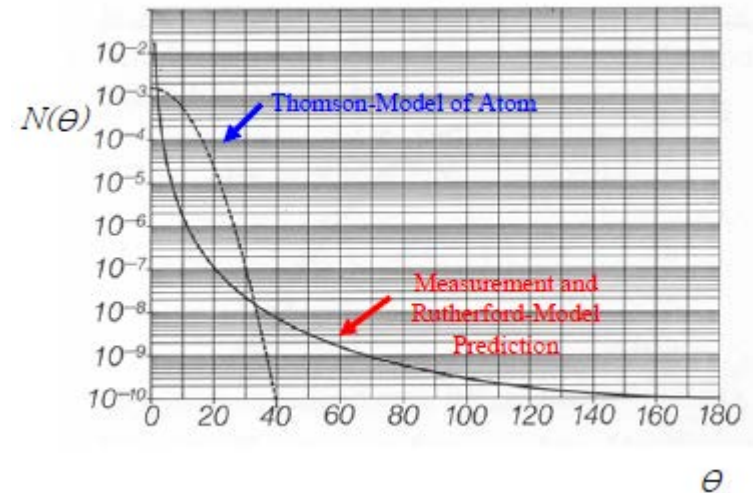

- ❖ 1919: E. Rutherford produced first nuclear reactions ${}^{14}\text{N} + {}^4\text{He} \rightarrow {}^{17}\text{O} + p$
prediction of neutrons
- ❖ H. Greinacher invents the cascade generator for several 100 keV.
- ❖ E. Rutherford is convinced that several 10 MeV are in general needed for nuclear reactions. He therefore gave up the thought of accelerating particles.

Tunneling allows low energies

- ❖ 1928: Explanation of alpha decay by George A. Gamov as tunneling showed that several 100 keV protons might suffice for nuclear reactions

Schrödinger equation:
$$\frac{\partial^2}{\partial r^2} u(r) = \frac{2m}{\hbar^2} [V(r) - E]u(r), \quad T = \left| \frac{u(L)}{u(0)} \right|^2$$

The transmission probability **T** for an alpha particle traveling from the inside towards the potential well that keeps the nucleus together determines the lifetime for alpha decay

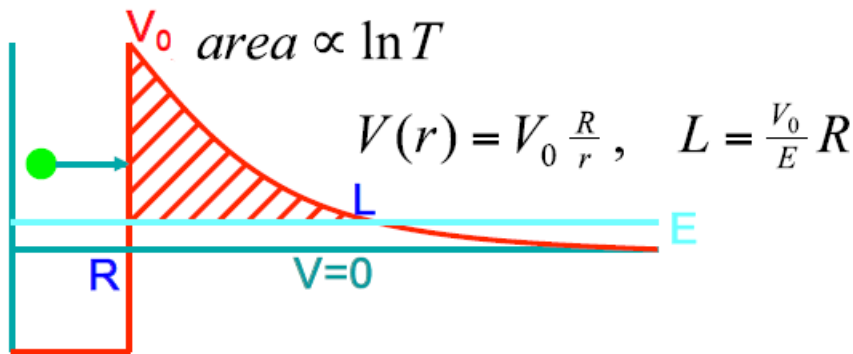

$$T \approx \exp\left[-2 \int_R^L \frac{\sqrt{2m[V(r)-E]}}{\hbar} dr\right]$$

$$\ln T \approx A - \frac{C}{\sqrt{E}}$$

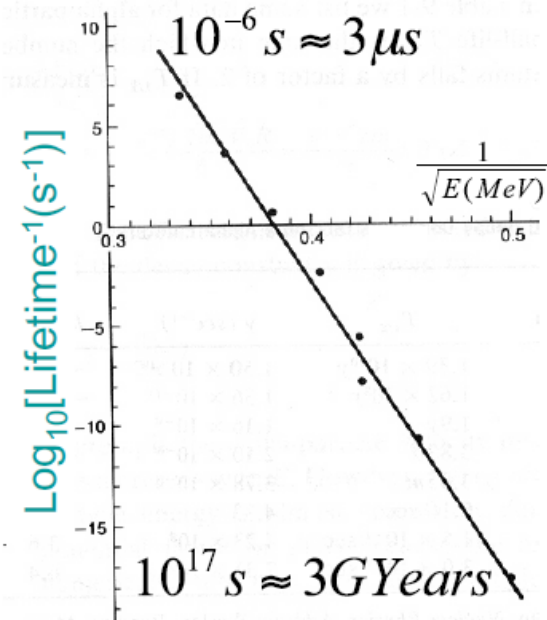

- ❖ 1932: first nuclear reaction with accelerated protons
 ${}^7\text{Li} + p \rightarrow 2\alpha$ ${}^7\text{Li} + p \rightarrow {}^7\text{Be} + n$ $E_p = 400 \text{ keV}$
 discovery neutron

Natural particle acceleration

- Radioactive sources produce maximum energies of a few million electron volts (MeV)
- **Cosmic rays** are high-energy radiation, mainly originating outside the Solar System and even from distant galaxies. Upon impact with the Earth's atmosphere, cosmic rays can produce showers of secondary particles that sometimes reach the surface.

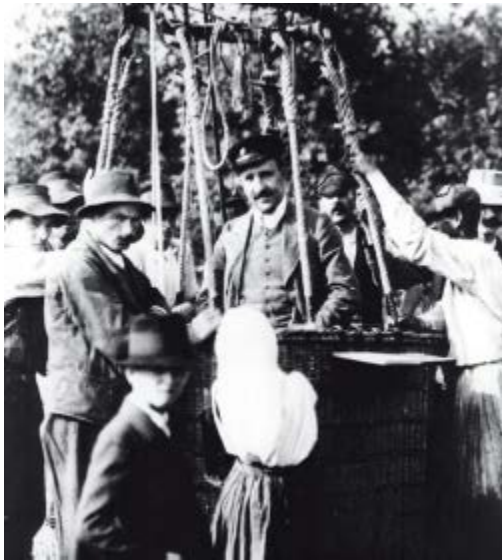

Victor Hess (1912)
discovery of cosmic showers

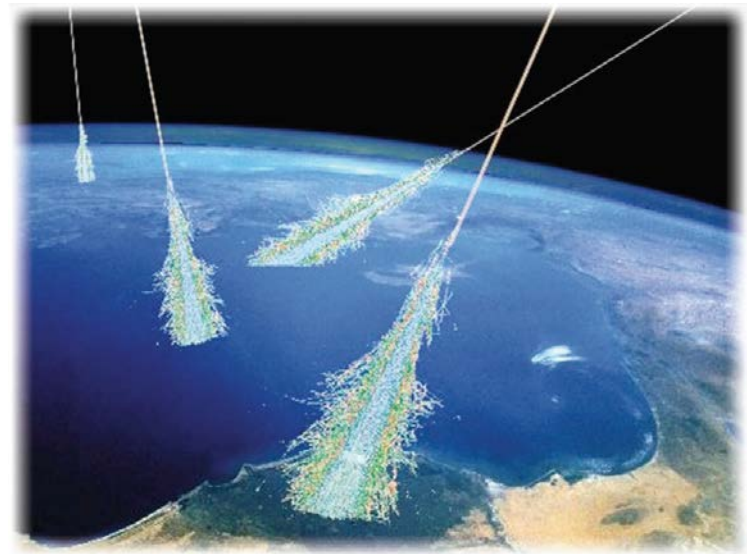

Natural particle acceleration

- Cosmic rays reach energies of $10^9 \cdot LHC$ but the rates are too low to be useful as a study tool
 - not enough luminosity
- However, low energy cosmic rays are extremely useful for detector testing, commissioning, etc.

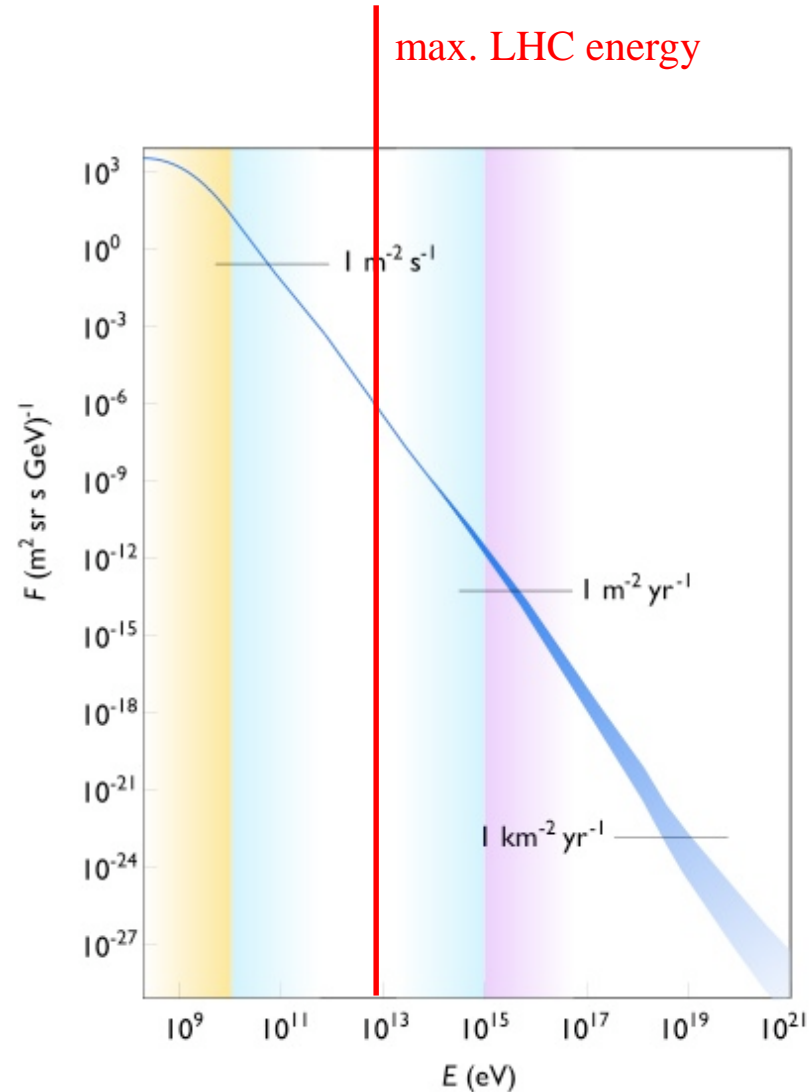

Basic acceleration principle

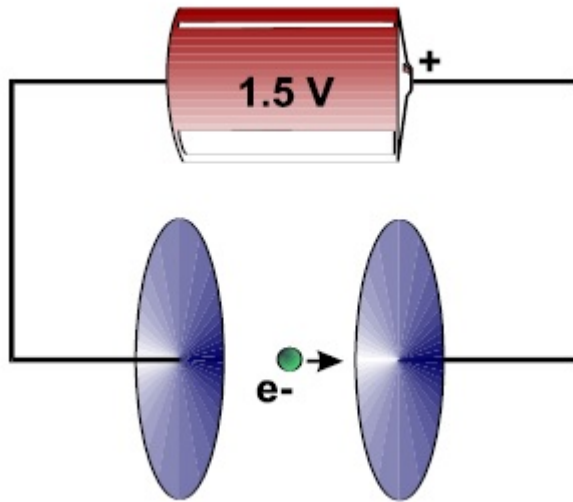

A voltage drop **accelerates** charged particles

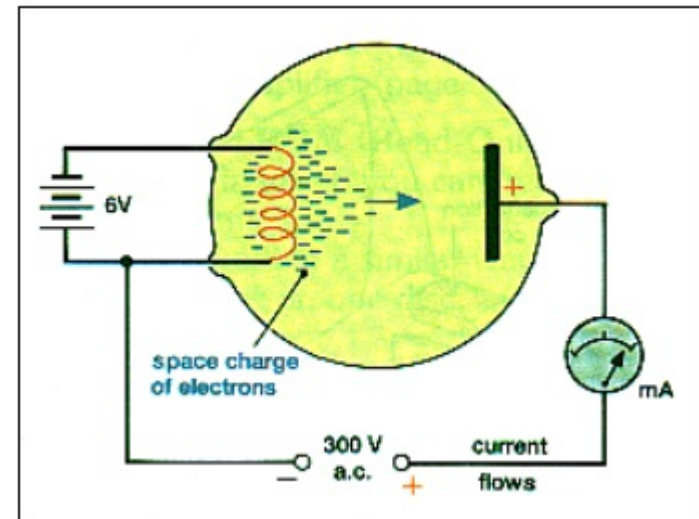

Three historical lines of accelerators

- ❖ Direct Voltage/Electrostatic Accelerators
- ❖ Resonant Accelerators
- ❖ Transformer Accelerator

General Principle and Limitations:

- Constant electric field between two electrodes
- One of the electrodes contains the particle source

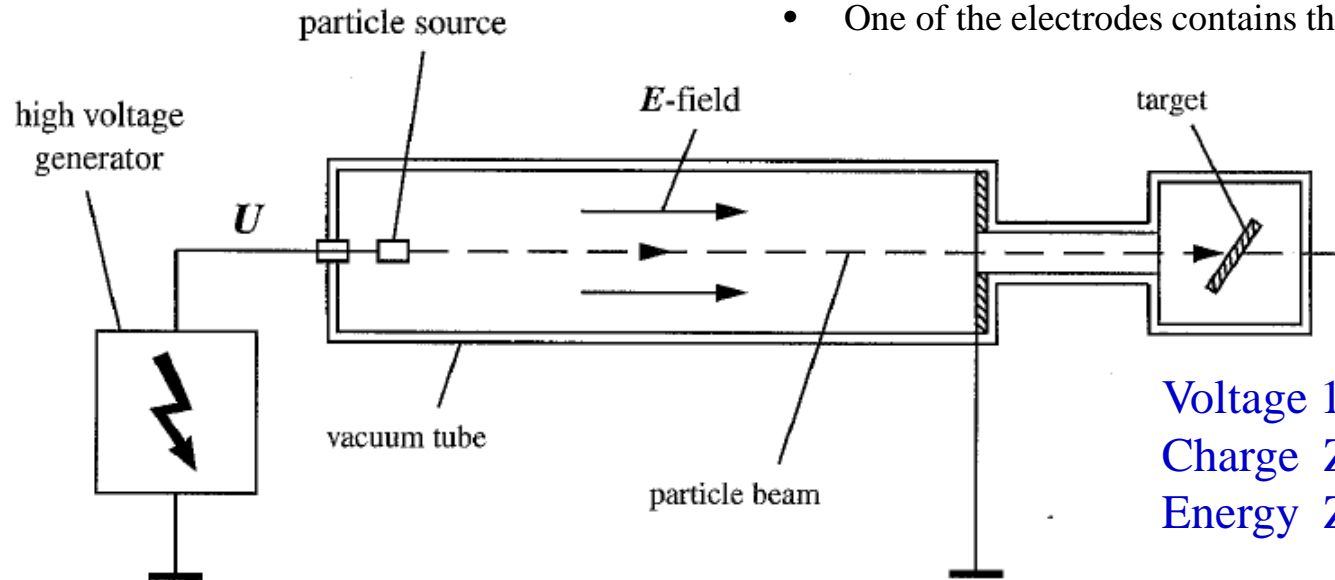

Voltage 1 MV
Charge Ze
Energy Z MeV

The energy limit is given by the maximum possible voltage. At the limiting voltage, electrons and ions are accelerated to such large energies that they hit the surface and produce new ions. An avalanche of charge carriers causes a large current and therefore a breakdown of the voltage.

- ❖ Maximum DC voltage: a few MV are technically possible



Acceleration by static electric fields

- ❖ We can produce an electric field by establishing a potential difference V_0 between two parallel plate electrodes, separated by a distance L :

$$E_z = V_0/L$$

- ❖ A charged particle released from the + *electrode* acquires an increase in kinetic energy at the - *electrode* of

$$\Delta W = \int_0^L F_z dz = q \int_0^L E_z dz = qV_0$$

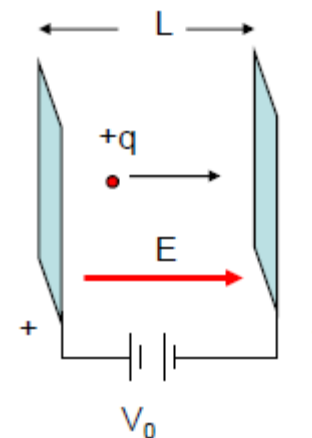

The simplest electrostatic accelerators: Electron Guns

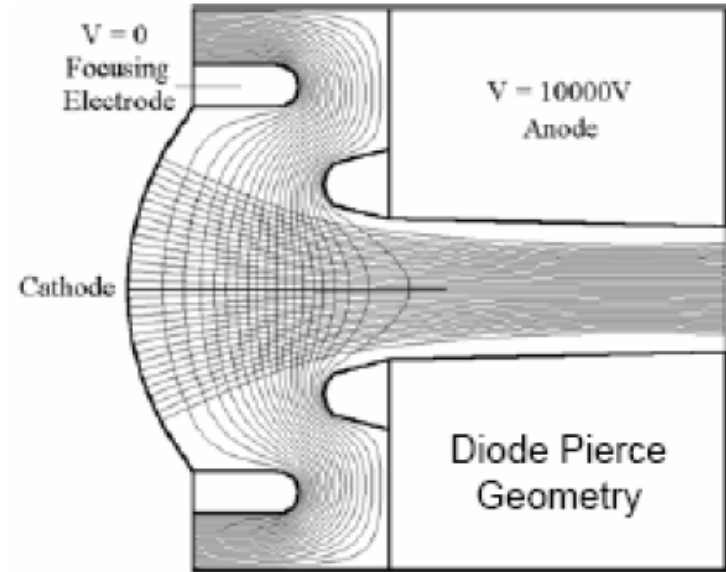
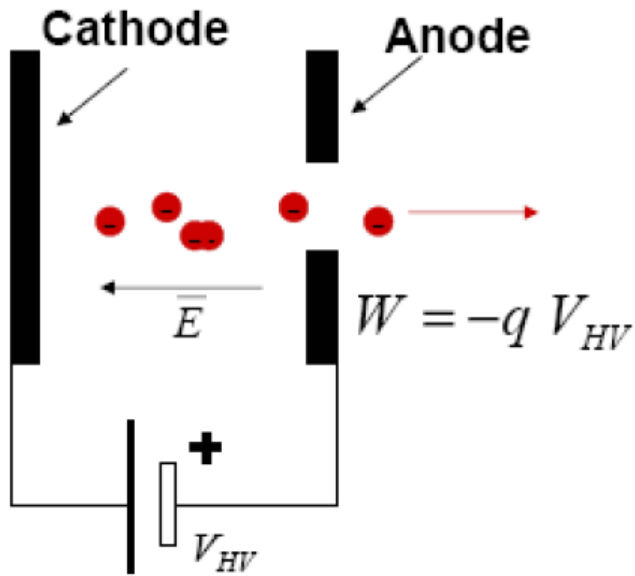

Still one of the most used schemes for electron sources

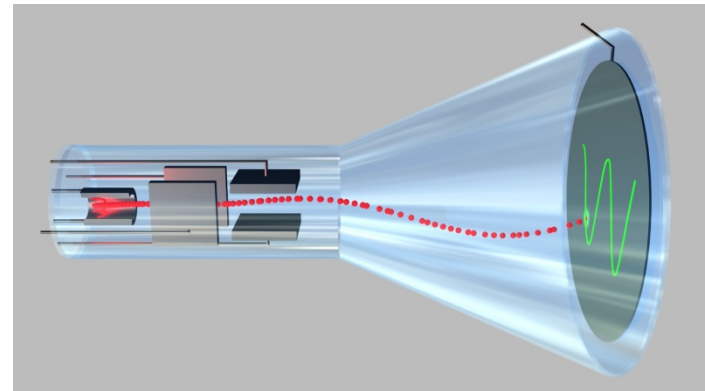
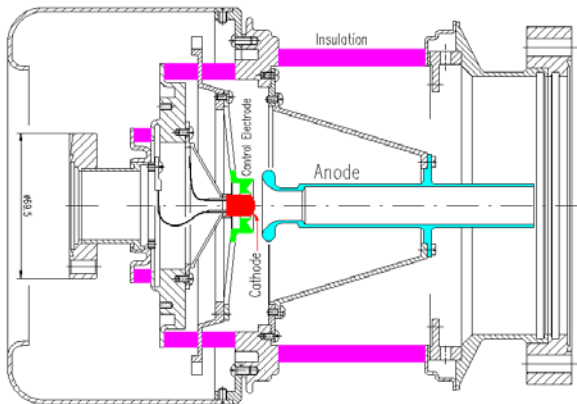

Electrostatic accelerators

- ❖ Some small accelerators, such as electron guns for TV picture tubes, used the parallel plate geometry.
- ❖ Electrostatic particle accelerators generally use a slightly modified geometry in which a constant electric field is produced across an accelerating gap

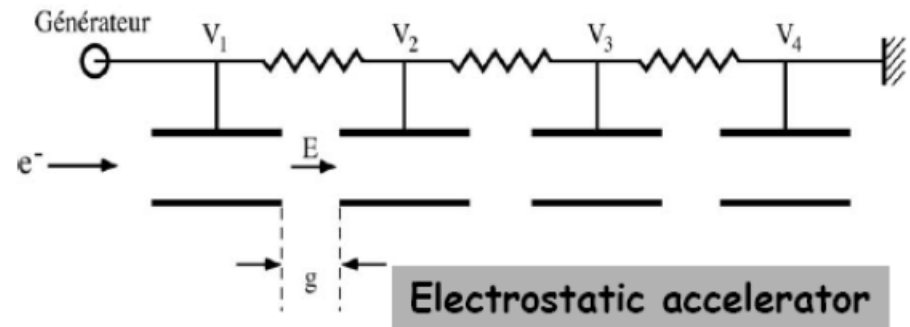

- ❖ Energy gain:

$$W = n \cdot q \sum V_n$$

- ❖ Limited by the generator

$$V_{generator} = \sum V_n$$

Accelerating column in electrostatic accelerator

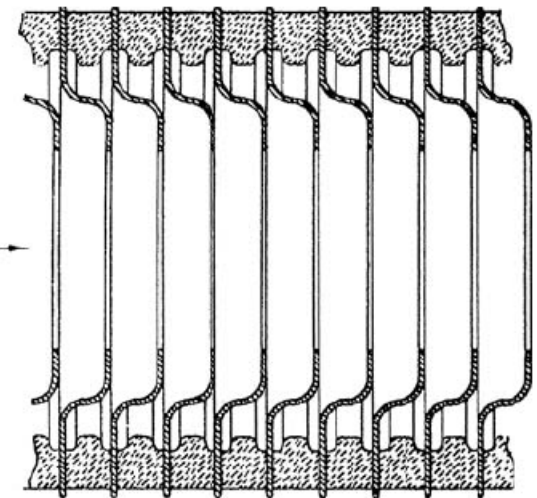

Cockroft Walton multiplier

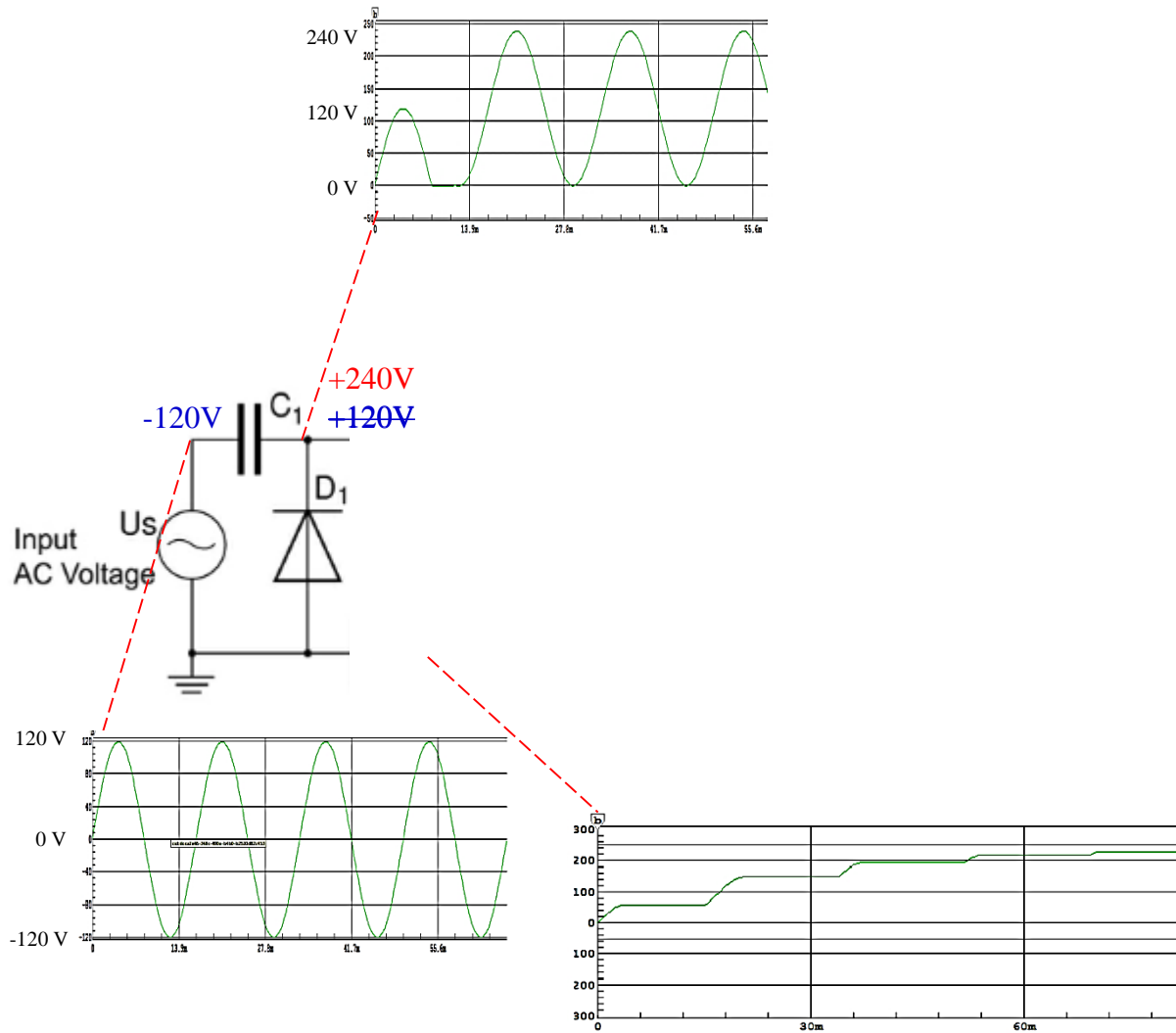

Walton, Rutherford, Cockcroft - 1932

Nobel Prize 1951

Cockcroft Walton multiplier

$$U_{total} = 2 \cdot n \cdot U - \frac{2 \cdot \pi \cdot I}{\omega \cdot C} \left(\frac{2}{3} n^3 + \frac{1}{4} n^2 + \frac{1}{12} n \right)$$

correction for current induced losses:

high frequency ω and large capacities C
reduce the influence of the current



high voltage generator $U = 400 \text{ kV}$

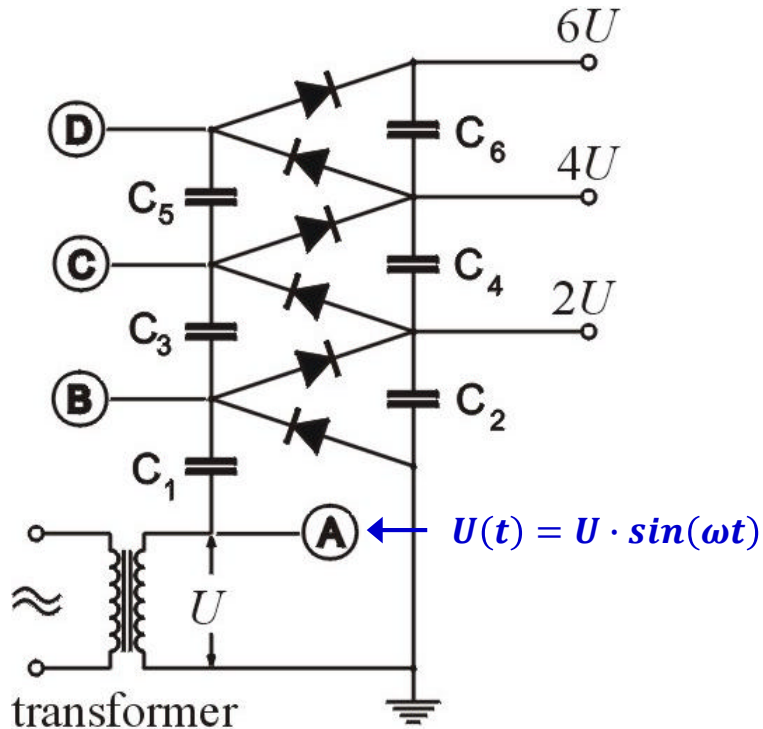

One could reach voltages of $U = 4 \text{ MV}$ and beam currents of 100 mA in pulse operation of μs range.

Van de Graaff accelerator

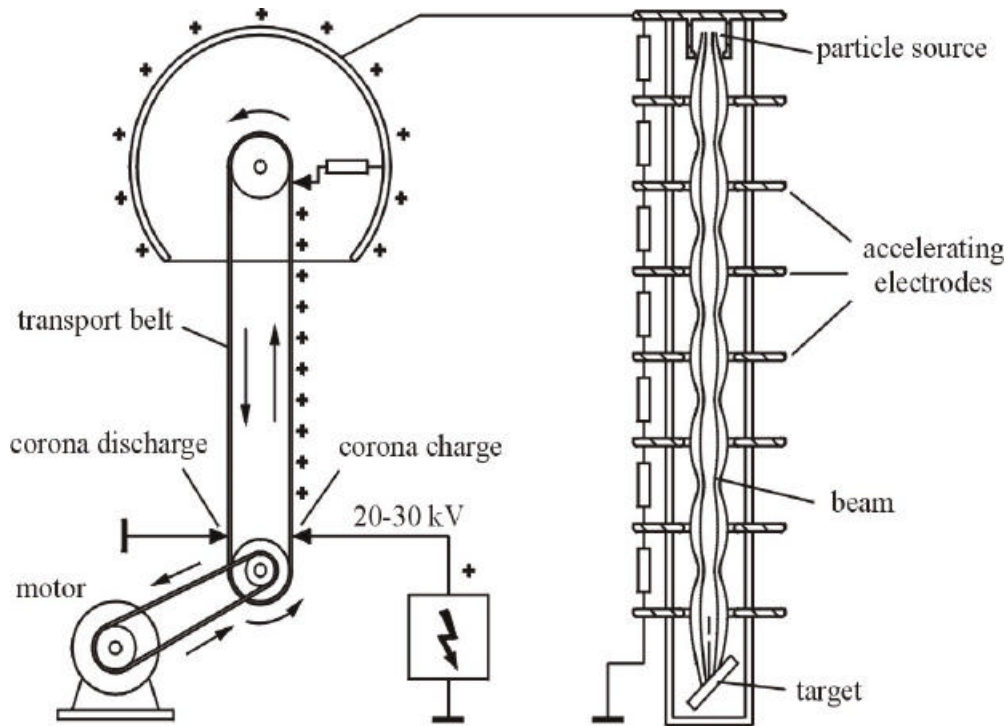

Van de Graaff - Daresbury



Robert Van de Graaff

- ❖ Creating high voltage by **mechanical transport of charges**
- ❖ The maximum achievable voltage in air at atmospheric pressure is about $U_{\max} = 2 \text{ MV}$.
- ❖ The use of compressed gas increases the break down potential. For purified sulfur hexafluoride (SF_6) at a pressure of $\sim 1 \text{ MPa}$ the maximum voltage is increased to $U_{\max} = 20 \text{ MV}$. It is however difficult to establish and maintain a static DC field of 20 MV.

Van de Graaff Generator

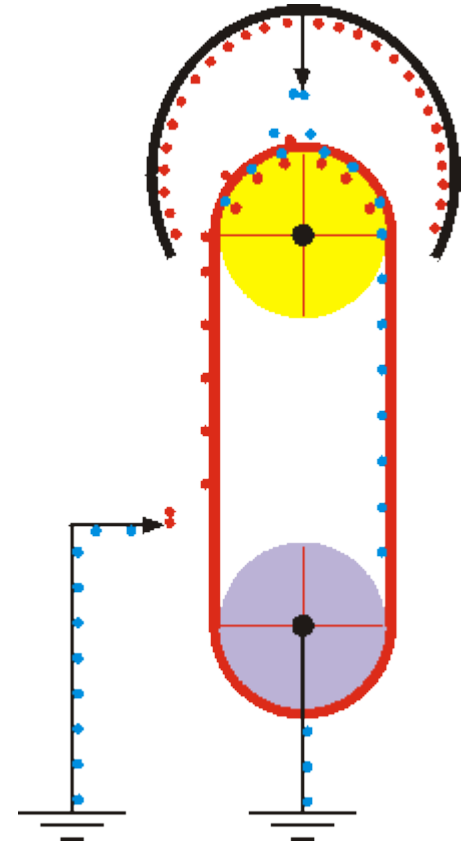
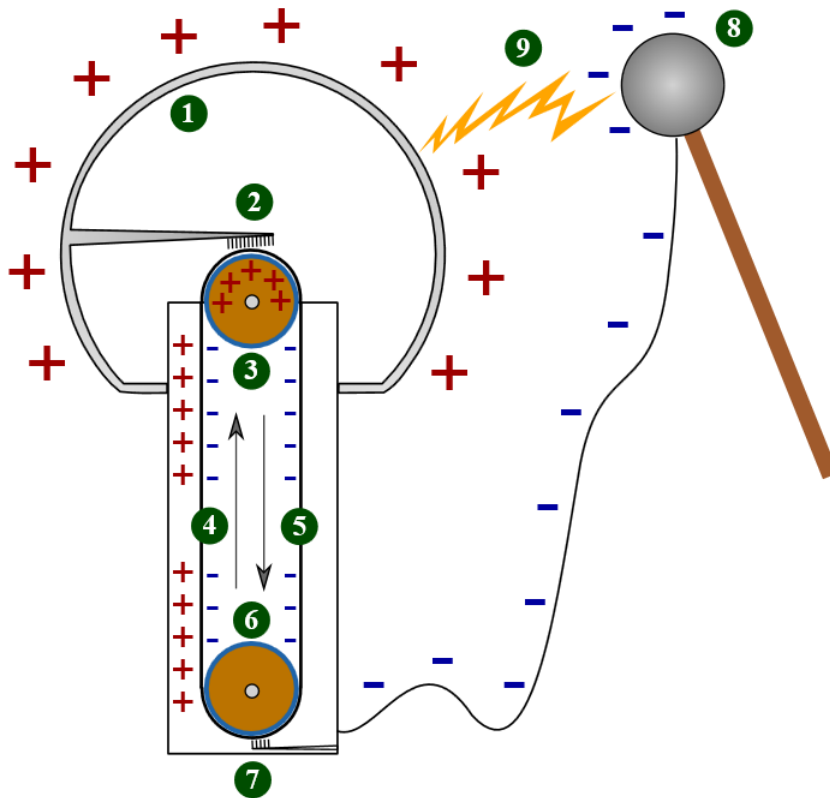

1. hollow metal sphere
2. upper electrode
3. upper roller (for example an acrylic glass)
4. side of the belt with positive charges
5. opposite side of belt, with negative charges
6. lower roller (metal)
7. lower electrode (ground)
8. spherical device with negative charges
9. spark produced by the difference of potentials

Current in electrostatic accelerator

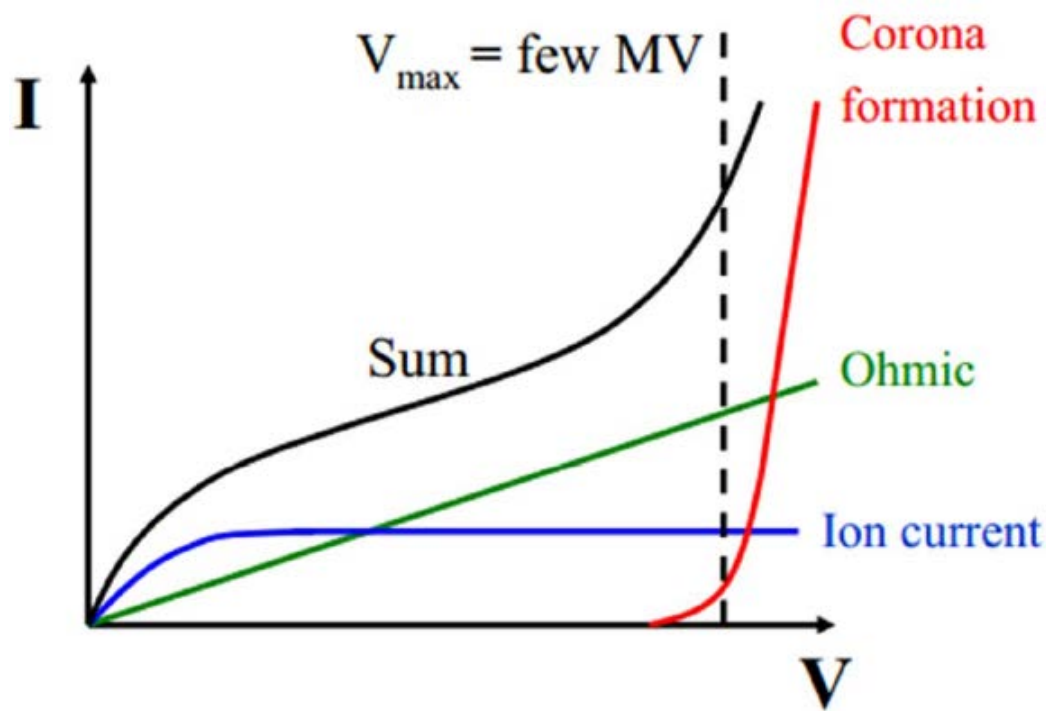

Dependence of the current on the applied voltage in electrostatic accelerator

- ❖ Since the conductivity of an insulator is never quite zero, there is always an **ohmic** component, which increases in proportion to the voltage.
- ❖ The **ions** are always present in the residual gas. It very quickly reaches a constant saturation level.
- ❖ The **corona formation** leads to the actual voltage limit. The field strength close to the electrodes grows so much that ions and electrons produced in this region are accelerated to considerable energies. They collide with gas molecules and so produce many more ions. The result is an avalanche of charge carriers causing **spark discharge** and the **breakdown of the high voltage**.

Tandem accelerator

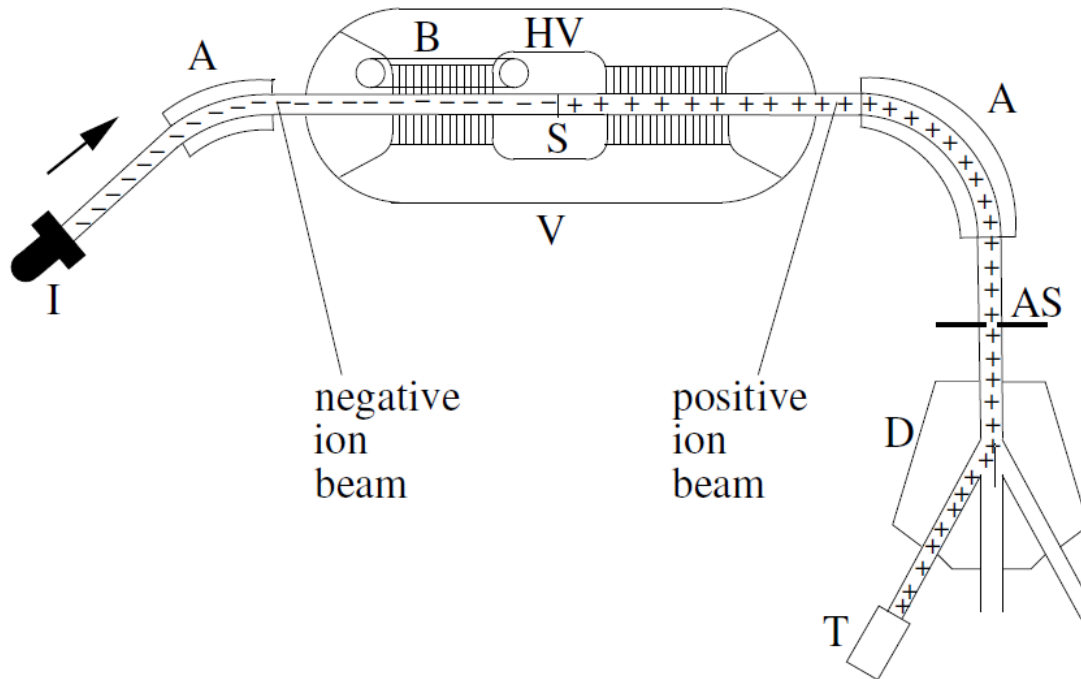

$$\begin{aligned} p, d &: T = 2 \text{ eU} \\ {}^2\text{He}^{2+}, {}^4\text{He}^{2+} &: T = 3 \text{ eU} \\ {}^{32}\text{S}^{16+} &: T = 17 \text{ eU} \end{aligned}$$



Tandem accelerator Munich

The Tandem accelerator utilizes the terminal high voltage twice. Negative ions produced by an appropriate ion source are accelerated from ground to the positively charged terminal. Inside the terminal is a stripper to remove electrons from the incoming negative ions. The now positively-charged ions experience a second boost of acceleration ('Tandem' accelerator).

IUAC tandem accelerator: terminal voltage 12.5 MV